



СМЫВОЧНЫЕ НОЖИ
WASH-UP BLADES FOR INK ROLLERS

Смывочные ножи Perfect Blades для печатных машин Heidelberg, Roland, Edelman, KBA, Ryobi и др. для разных типов печати.

PERFECT BLADES

®



Смычочные ножи изготавливаются по специально разработанной технологии, которые делают их качественно "уникальный" в своем роде

ОСТЕРЕГАЙТЕСЬ ПОДДЕЛОК!

Смычочные ножи изготовлены с использованием исключительно высококачественных и первого класса материалов.

Гарантировать качество, поддержку и гарантии может только приобретение у авторизованных поставщиков.

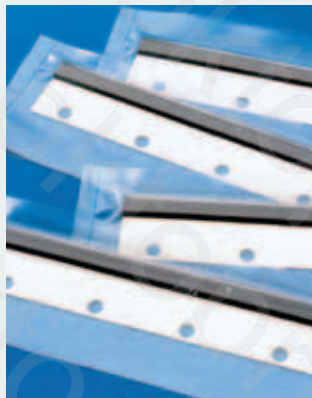

Our wash-up blades are produced using sophisticated production procedures which make them qualitatively "unique" in their kind.

BEWARE OF IMITATIONS!!

Our wash-up blades are manufactured using top quality and first class materials. The quality standard that we alone can produce, supply and guarantee.



Смычочные ножи "Perfect Blades" изготовлены из закаленной стали высокого качества.

Our "Perfect Blades" wash-up blades are manufactured using top quality glazed hardened steel.



В полтора раза прочнее продукции других производителей
50% longer durability compared to competitors' products.



Ножи других производителей отличаются по цвету
Competitors' blades made with coloured iron.



PERFECT BLADES



INDICE - INDEX - INDICE

AB DICK	203	LABELMAN	209
ADAST/DOMINANT	203	MABER	209
AKIRA	209	MACCHINE PER ETICHETTE - LABEL PRINTING PRESSES - MAQUINAS PARA ETIQUETAS	206-207
AKIYAMA	198	MAGNUM	208
ALBERT FRANKENTAL	200	MAILÄNDER	201
ALPHA GIKEN	211	MANROLAND	193-194
ARSOMA	211	MIEHLE	200
ATM	210	MILLER	200
AURELIA/OMCSA/REDAELLI	202	MITSUBISHI	197
AUTOMATION	211	MIYAKOSHI	204
BAKER PERKINS	211	MODELLI VARI	208
BIELOMATIC	211	MORGAN	210
CERUTTI	208	MÜLLER MARTINI	204
CHAMBON	210	MULTILITH	203
C.M.C. CARDANI	209	NEBIOLO	202
CODIMAG	204	NEBIOLO	202
COLORJET	207	TIPOGRAFICHE - TYPOGRAPHIC - TIPOGRAFICA	
COLOR METAL	211	NEW MEC	208
CONSERVER PRESS	208	NILPETER	206
CRABTREE	201	ORIS	209
DAVIDSON	201	PLANETA	196
DIDDE	207	POLLY	211
DOVERSTAR	207	ROCKWELL GOSS	205
DRENT	205	ROLAND/M.A.N.	193
EDELMANN	194	ROTAPRINT	202
EPIKOS	211	ROTATEK	203
FAG TORCHIO TIRAPROVE	209	RYOBI	198
FLEXI BOBINE	206	SAKURAY	198
FORM CONSULTA	208	SANCKI	207
FUJI PRIMEX	201	SANJO	209
GALLUS	206	SCHRIBER	207
GESTETNER	203	SHINOHARA/FUJI	199
GIBLER	207	SOLNA INTERNATIONAL	201
GOEBEL	204	STEVENS	207
GUANG	211	TAIYO	210
HAMADA	199	TIMSONS	205
HAMILTONS	210	TKS	211
HANTSHO	201	TOKO	210
HARRIS ROTATIVE/WEB OFFSET	200	TOSHIBA	209
HASHIMOTO	199	UKITA	207
HEAT	211	WEILAND	206
HEIDELBERG	192-193	WIFAG	205
IMER	208	WINCLER	208
INDIGO	211	ZIRKON	210
IWASAKI TEKKO	206		
KBA KOENIG & BAUER PLANETA	195		
KBA WEB OFFSET	195		
КВА ГАЗЕТНАЯ РОТАЦИЯ - WEB PRESS FOR NEWSPAPERS	195		
KO/PAK	209		
KOMORI	196-197		
KOREX TORCHIO TIRAPROVE	209		

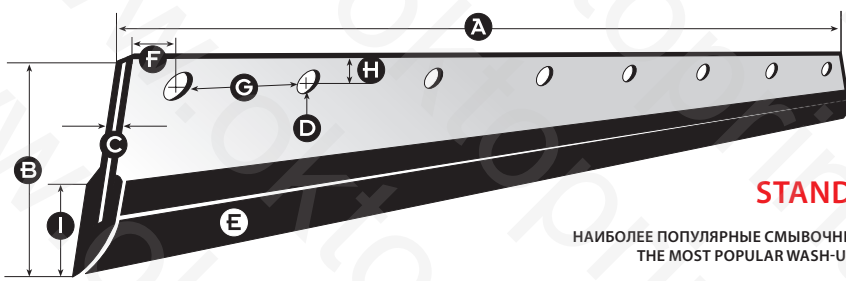

STANDARD

НАИБОЛЕЕ ПОПУЛЯРНЫЕ СМЫВОЧНЫЕ НОЖИ
THE MOST POPULAR WASH-UP BLADES

ВАЖНО: ПРИ ЗАКАЗЕ СМЫВОЧНЫХ НОЖЕЙ СО СПЕЦИАЛЬНОЙ EPDM-РЕЗИНОЙ ДЛЯ УФ-КРАСКИ ЦЕНА ВОЗРАСТАЕТ НА 15%
IMPORTANT: FOR ORDERS OF WASH-UP BLADES WITH THE SPECIAL "EPDM" RUBBER PROFILE FOR "UV" INK: 15% PRICE INCREASE

	ЛЕГЕНДА	КЕУ
A =	Длина	Length
B =	Ширина	Width
C =	Толщина	Thickness
D =	Количество отверстий	N° of holes
E =	Тип ножа	Blade type
M =	Металл	Metal
R =	Резина	Rubber
MR =	Металл + Резина	Metal + Rubber
F =	Ламинированная Фибра	Laminated Fibre
P =	Пластик	Plastic
T =	Тефлон	Teflon
V =	Вулколлан	Vulcollan

HEIDELBERG

КОД КОДЕ	МОДЕЛЬ МАШИНЫ - MACHINE & MODEL	РАЗМЕР SIZE	A		B		C		D	E
			MM	INCHES	MM	INCHES	MM	INCHES		
100	ТОК	28 x 39	283	11,14"	43	1,69"	3	0,12"	4	P
105	QUICKMASTER/PRINTMASTER QM 46	34 x 46	375	14,76"	43	1,69"	3	0,12"	5	P
107	QUICKMASTER/PRINTMASTER QM 46 (Для нумер.секции/Numbering unit)	32 x 46	343	13,50"	20	0,79"	1	0,04"	5	P
110	GTO-46 (СТАНДАРТНЫЙ - STANDARD)	32 x 46	500	19,69"	60	2,36"	0,5	0,02"	5	MR
115	GTO-46 (Для нумер.секции/Numbering unit)	32 x 46	448	17,64"	40	1,57"	6	0,24"	3	F
120	GTO-52 (СТАНДАРТНЫЙ - STANDARD)	36 x 52	560	22,05"	60	2,36"	0,5	0,02"	6	MR
125	GTO-52 (Для нумер.секции/Numbering unit)	36 x 52	508	20,00"	40	1,57"	6	0,24"	3	F
127	PRINTMASTER 52	36 x 52	565	22,24"	60	2,36"	0,5	0,02"	6	MR
130	SPEEDMASTER 52 (СТАНДАРТНЫЙ - STANDARD)	37 x 52	605	23,82"	47	1,85"	0,5	0,02"	7	MR
131	SPEEDMASTER 52 (Для нумер.секции/Numbering unit)	37 x 52	536	21,10"	28	1,10"	0,5	0,02"	6	MR
135	KOR-57	40 x 57	600	23,62"	51	2,01"	2	0,08"	10	MR
140	KORA-57	46 x 57	622	24,49"	51	2,01"	2	0,08"	10	MR
145	KORD-62	46 x 62	650	25,59"	51	2,01"	2	0,08"	10	MR
150	KORD-64 (СТАНДАРТНЫЙ - STANDARD)	46 x 64	690	27,17"	51	2,01"	2	0,08"	12	MR
155	KORS-72 (СТАНДАРТНЫЙ - STANDARD)	52 x 72	760	29,92"	51	2,01"	2	0,08"	12	MR
160	MO-65/MOVP65 (СТАНДАРТНЫЙ - STANDARD)	48 x 65	710	27,95"	60	2,36"	0,5	0,02"	8	MR
165	MO-65/MOVP65 (Для офсетной резины /For blanket)	48 x 65	692	27,24"	60	2,36"	0,5	0,02"	7	MR
170	MO-65 (Для нумер.секции/Numbering unit)	48 x 65	648	25,51"	52	2,05"	6	0,24"	3	F
175	SORK-65 (Новая модель/New model 0,5 мм.-0,02" Гибкий/Flexible)	48 x 65	710	27,95"	60	2,36"	0,5	0,02"	8	MR
180	SORK-65 (Старая модель/Old model 2мм.-0,08" Жесткий/Rigid)	48 x 65	720	28,35"	51	2,01"	2	0,08"	12	MR
185	SORM-Z (Новая модель/New model 0,5 мм.-0,02" Гибкий/Flexible)	52 x 74	790	31,10"	60	2,36"	0,5	0,02"	11	MR
190	SORM (Старая модель/Old model 2мм.-0,08" Жесткий/Rigid)	52 x 72	790	31,10"	51	2,01"	2	0,08"	12	MR
195	SPEEDMASTER 72 - (СТАНДАРТНЫЙ - STANDARD)	52 x 72	790	31,10"	60	2,36"	0,5	0,02"	11	MR
200	SPEEDMASTER 72 - VP (спазами - special white slots)	52 x 72	753	29,65"	40	1,57"	0,5	0,02"	9	MR
205	SPEEDMASTER 72 (Автосмывка /Autowash)	52 x 72	742	29,21"	60	2,36"	0,5	0,02"	8	MR
210	SPEEDMASTER/PRINTMASTER 74 (СТАНДАРТНЫЙ - STANDARD)	52 x 74	822	32,36"	57	2,24"	0,5	0,02"	9	MR
211	SPEEDMASTER/PRINTMASTER 74 (СТАНДАРТНЫЙ - STANDARD)	52 x 74	826	32,52"	57	2,24"	0,5	0,02"	9	MR
212	SPEEDMASTER 74 (Для УФ красок /For "UV" inks/) Teflon	52 x 74	826	32,52"	58	2,28"	5	0,20"	9	T
213	SPEEDMASTER 74 (Для УФ красок /For "UV" inks/) Vulcollan	52 x 74	826	32,52"	58	2,28"	5	0,20"	9	V
214	SPEEDMASTER/PRINTMASTER 74 "SPECIAL" DOUBLE ROW OF HOLES	52 x 74	826	32,52"	57	2,24"	0,5	0,02"	18	MR
215	SPEEDMASTER 74 (Автосмывка /Autowash)	52 x 74	748	29,45"	57	2,24"	0,5	0,02"	8	MR
216	SPEEDMASTER 74 (С лакированной секцией /Varnish group)	54 x 74	846	33,31"	47	1,85"	0,5	0,02"	9+2	MR
217	SPEEDMASTER 74 CD (NEW MODEL)	54 x 74	846	33,31"	47	1,85"	0,5	0,02"	9+2	MR
218	SPEEDMASTER 75 XL									
220	SOR-82 (Новая модель/New model 0,5мм.-0,02" Гибкий/Flexible)	61 x 82	890	35,04"	60	2,36"	0,5	0,02"	9	MR
225	SOR-82 (Старая модель/Old model 2мм.-0,08" Rigida/Rigid/Rigida)	61 x 82	890	35,04"	51	2,01"	2	0,08"	10	MR
230	SORD (Новая модель/New model 0,5мм.-0,02" Гибкий/Flexible)	64 x 91,5	960	37,80"	60	2,36"	0,5	0,02"	10	MR
235	SORD (Старая модель/Old model 2мм.-0,08" Rigida/Rigid/Rigida)	64 x 89	960	37,80"	51	2,01"	2	0,08"	12	MR
237	SORD-Z (Для печатной секции - Print unit)	64 x 91,5	926	36,46"	40	1,57"	0,5	0,02"	10	MR
240	ROTASPEED-102	71 x 102	1050	41,34"	60	2,36"	0,5	0,02"	11	MR
245	SORS-Z-102 (СТАНДАРТНЫЙ - STANDARD)	72 x 102	1090	42,91"	60	2,36"	0,5	0,02"	11	MR
250	SPEEDMASTER 102 (СТАНДАРТНЫЙ - STANDARD)	72 x 102	1090	42,91"	60	2,36"	0,5	0,02"	11	MR
251	SPEEDMASTER 102 (Для УФ красок /For "UV" inks/) Vulcollan	72 x 102	1090	42,91"	60	2,36"	5	0,20"	11	V
255	SPEEDMASTER 102 VP (Специальный - Special)	72 x 102	1052	41,42"	40	1,57"	0,5	0,02"	11	MR
260	SPEEDMASTER 102 (Автосмывка /Autowash)	72 x 102	1042	41,02"	57	2,24"	0,5	0,02"	11	MR
265	SPEEDMASTER 102 CD (СТАНДАРТНЫЙ - STANDARD)	72 x 102	1090	42,91"	57	2,24"	0,5	0,02"	11	MR
266	SPEEDMASTER 102 CD (Для УФ красок /For "UV" inks/) Vulcollan	72 x 102	1090	42,91"	57	2,24"	5	0,20"	11	V
268	SPEEDMASTER 105 XL	75 x 105	1125	44,29"	41	1,61"	0,5	0,02"	15+6	MR
269	SPEEDMASTER 105 XL (Для УФ красок /For "UV" inks/) Vulcollan	75 x 105	1125	44,29"	41	1,61"	5	0,20"	21 (15+6)	V
272	SPEEDMASTER 142 XL									
274	SPEEDMASTER 162 XL									
	WEB - 8 - HEIDELBERG/HARRIS рулонный офсет 8 страниц /web offset 8 pages		570	22,44"	51	2,01"	2	0,08"	8	MR
280	WEB - MC 110 - HEIDELBERG/HARRIS Рулонный офсет /Web offset		760	29,92"	70	2,76"	0,5	0,02"	8	MR
285	WEB - 16 - HEIDELBERG/HARRIS M600 рулонный офсет 16 страниц /web offset 16 pages		1036	40,79"	51	2,01"	2	0,08"	12	MR
287	WEB - 8 система охлаждения /cooling system		600	23,62"	60	2,36"	0,5	0,02"	6	MR
289	HEIDELBERG - M 4000 - WEB - HARRIS SUNDAY 64 PAG		2035	80,12"	60	2,36"	0,5	0,02"	22	MR

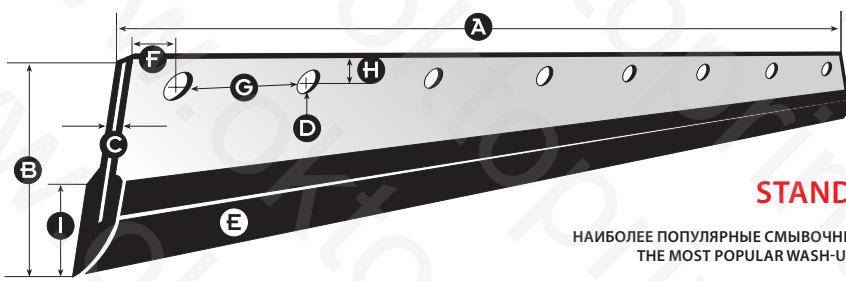

STANDARD

НАИБОЛЕЕ ПОПУЛЯРНЫЕ СМЫВОЧНЫЕ НОЖИ
THE MOST POPULAR WASH-UP BLADES

ВАЖНО: ПРИ ЗАКАЗЕ СМЫВОЧНЫХ НОЖЕЙ СО СПЕЦИАЛЬНОЙ ЕРДМ-РЕЗИНОЙ ДЛЯ УФ-КРАСКИ ЦЕНА ВОЗРАСТАЕТ НА 15%
IMPORTANT: FOR ORDERS OF WASH-UP BLADES WITH THE SPECIAL "EPDM" RUBBER PROFILE FOR "UV" INK: 15% PRICE INCREASE

	ЛЕГЕНДА	КЕY
A =	Длина	Length
B =	Ширина	Width
C =	Толщина	Thickness
D =	Количество отверстий	N° of holes
E =	Тип ножа	Blade type
M =	Металл	Metal
R =	Резина	Rubber
MR =	Металл + Резина	Metal + Rubber
F =	Ламинированная Фибра	Laminated Fibre
P =	Пластик	Plastic
T =	Тефлон	Teflon
V =	Вулколан	Vulcollan

MANROLAND

КОД КОДЕ	МОДЕЛЬ МАШИНЫ - MACHINE & MODEL	РАЗМЕР SIZE	A		B		C		D	E
			MM	INCHES	MM	INCHES	MM	INCHES		
533	M.A.N.	78 x 108	1156	45,51"	65	2,56"	0,5	0,02"	6	MR
532	M.A.N. 5 - GS	80 x 120	1280	50,39"	78	3,07"	0,5	0,02"	14	MR
535	M.A.N. GS 140	100 x 140	1436	56,54"	78	3,07"	0,5	0,02"	15	MR
540	M.A.N. G 140	100 x 140	1540	60,63"	60	2,36"	0,5	0,02"	12	MR
542	M.A.N. GS 140	100 x 140	1550	61,02"	78	3,07"	0,5	0,02"	16	MR
545	M.A.N. GS 160	120 x 160	1614	63,54"	78	3,07"	0,5	0,02"	17	MR
550	M.A.N. G 160	110 x 160	1749	68,86"	78	3,07"	0,5	0,02"	19	MR
552	M.A.N. G 160	110 x 160	1749	68,86"	92	3,62"	0,5	0,02"	19	MR
558	ULTRA M.A.N. Резина/Rubber	72 x 102	1060	41,73"	37	1,46"	5	0,20"	0	R
560	ULTRA M.A.N. Резина/Rubber	90 x 132	1400	55,12"	30	1,18"	5	0,20"	0	R
565	COLORMAN	WEB OFFSET	1400	55,12"	65	2,56"	0,5	0,02"	14	MR
566	COLORMAN - (PLAN 29)	WEB OFFSET	1670	65,75"	65	2,56"	0,5	0,02"	16	MR
566-A	COLORMAN - (PLAN 88)	WEB OFFSET	1670	65,75"	64	2,52"	0,5	0,02"	18	MR
567	M.A.N. Резина/Rubber	100 x 140	1500	59,06"	25	0,98"	5	0,20"	0	R
568	COLORMAN 35 - (PLAN 32)	WEB OFFSET	1530	60,47"	65	2,56"	0,5	0,02"	16	MR
569	M.A.N. GEOMAN (PLAN 37)	WEB OFFSET	1530	60,47"	65	2,56"	0,5	0,02"	8	MR
570	LITHO - M.A.N.	100 x 140	1552	61,10"	65	2,56"	0,5	0,02"	16	MR
571	ULTRA - M.A.N.	100 x 140	1593	62,72"	64	2,52"	0,5	0,02"	17	MR
575	LITHO - M.A.N.	120 x 160	1700	66,93"	65	2,56"	0,5	0,02"	16	MR
577	ROLAND - M.A.N. (PLAN 25)	120 x 160	1730	68,11"	65	2,56"	0,5	0,02"	9	MR
579	ROLAND - ULTRA/M.A.N. ULTRA VII ° G	120 x 160	1755	69,09"	70	2,76"	0,5	0,02"	13	MR
579-A	ROTOMAN - POLYMAN		1036	40,79"	64	2,52"	0,5	0,02"	9	MR
580	ROTOMAN (PLAN 55)	WEB OFFSET	1040	40,94"	65	2,56"	0,5	0,02"	6	MR
583	ROTOMAN - M - (PLAN 90)	WEB OFFSET	1040	40,94"	65	2,56"	0,5	0,02"	10	MR
581	LITHOMAN 1/5 (PLAN 14)	WEB OFFSET	1136	44,72"	64	2,52"	0,5	0,02"	9	MR
582	COLORMAN (PLAN 52)	WEB OFFSET	1340	52,76"	65	2,56"	0,5	0,02"	7	MR
588	ROTOMAN 8 (8 PAGES)	WEB OFFSET	1038	40,87"	65	2,56"	0,5	0,02"	10	MR
589	MAN - UNISET - PLAMAG CHROMOSET (PLAN 66)	WEB OFFSET	1000	39,37"	64	2,52"	0,5	0,02"	11	MR
590	ROTOMAN	WEB OFFSET	1060	41,73"	65	2,56"	0,5	0,02"	9	MR
595	ROTOMAN Пластик/Plastic	WEB OFFSET	1060	41,73"	68	2,68"	1	0,04"	9	P
598	LITHOMAN III°	WEB OFFSET	864	34,02"	65	2,56"	0,5	0,02"	7	MR
599	LITHOMAN (PLAN 78)	WEB OFFSET	1332	52,44"	65	2,56"	0,5	0,02"	6	MR
600	LITHOMAN III° - 6/7 - MAN GEOMAN - (PLAN 13) (PLAN 8)	WEB OFFSET	1335	52,56"	65	2,56"	0,5	0,02"	7	MR
605	LITHOMAN IV°	WEB OFFSET	1020	40,16"	65	2,56"	0,5	0,02"	8	MR
610	LITOMAN	WEB OFFSET	1477	58,15"	90	3,54"	0,5	0,02"	16	MR
615	POLYMAN/ROTOMAN	WEB OFFSET	1036	40,79"	65	2,56"	0,5	0,02"	10	MR
620	OCTOMAN	WEB OFFSET	743	29,25"	55	2,17"	0,5	0,02"	12	MR
625	COLORMAN	WEB OFFSET	1330	52,36"	65	2,56"	0,5	0,02"	7	MR
626	UNIMAN	WEB OFFSET	1760	69,29"	65	2,56"	0,5	0,02"	9	MR
627	LITHOMAN	WEB OFFSET	1467	57,76"	50	1,97"	0,5	0,02"	13	MR
628	LITHOMAN	WEB OFFSET	1516	59,69"	65	2,56"	0,5	0,02"	13	MR
629	LITHOMAN	WEB OFFSET	1468	57,80"	65	2,56"	0,5	0,02"	12	MR
633	COLORMAN (PLAN 61)	WEB OFFSET	1850	72,83"	65	2,56"	0,5	0,02"	17	MR
630	LITHOMAN	WEB OFFSET	2060	81,10"	65	2,56"	0,5	0,02"	11	MR
631	COLORMAN	WEB OFFSET	2070	81,50"	70	2,76"	0,5	0,02"	13	MR
634	COLORMAN (PLAN 65)	WEB OFFSET	2080	81,89"	65	2,56"	0,5	0,02"	0	MR
632	MAN - GEOMAN (PLAN 44)	WEB OFFSET	2140	84,25"	64	2,52"	0,5	0,02"	11	MR

EDELMANN (MANROLAND) FORM ALL - БЕСКОНЕЧНЫЕ ФОРМУЛЯРЫ - CONTINUOUS FORM

КОД КОДЕ	МОДЕЛЬ МАШИНЫ - MACHINE & MODEL	РАЗМЕР SIZE	A		B		C		D	E
			MM	INCHES	MM	INCHES	MM	INCHES		
2610	PAK PRINT/WEB PRINT 39/JUNIOR/EXTREME V38		415	16,34"	60	2,36"	0,5	0,02"	5	MR
2615	FORM PRINT V38 (DRAWING - A)		415	16,34"	60	2,36"	0,5	0,02"	9	MR
2616	FORM ALL		415	16,34"	55	2,17"	3	0,12"	9	P
2620	FORM PRINT (SPECIAL)		490	19,29"	65	2,56"	0,5	0,02"	15	MR
2625	MINI PRINT		550	21,65"	58	2,28"	0,5	0,02"	6	MR
2630	VARIOPRINT 52		576	22,68"	60	2,36"	0,5	0,02"	6	MR
2635	FORM PRINT 47		487	19,17"	60	2,36"	0,5	0,02"	10	MR
2640	WEB PRINT 48 - FIVE		513	20,20"	60	2,36"	0,5	0,02"	6	MR
2645	JUNIOR PRINT		410	16,14"	60	2,36"	0,5	0,02"	9	MR
2650	WEB PRINT 39									
2653	COLOR PRINT - V 52		572	22,52"	58	2,28"	0,5	0,02"	6	MR
2655	COLOR PRINT		774	30,47"	58	2,28"	0,5	0,02"	8	MR
2656	WEB 48		520	20,47"	60	2,36"	0,5	0,02"	11	MR

KBA - KOENIG & BAUER PLANETA

КОД CODE	МОДЕЛЬ МАШИНЫ - MACHINE & MODEL	РАЗМЕР SIZE	A		B		C		D	E
			MM	INCHES	MM	INCHES	MM	INCHES		
655	KARAT 46		389	15,31"	25	0,98"	5	0,20"	7	V
657	KARAT 74									
680	KBA - SRO 72 - Пластик/Plastic	52 x 72	770	30,31"	50	1,97"	1	0,04"	8	P
685	KBA - SRO 72 - Старая модель/Old model	52 x 72	770	30,31"	50	1,97"	0,5	0,02"	8	MR
690	KBA RAPIDA 72/74 - Новая модель/New model - СТАНДАРТНЫЙ - STANDARD	52 x 72	780	30,71"	46	1,81"	0,5	0,02"	11	MR
691	KBA RAPIDA 74 - Пластик/Plastic	54 x 74	780	30,71"	40	1,57"	1	0,04"	11	P
693	KBA - 74 PERFORMA	54 x 74	800	31,50"	25	0,98"	3	0,12"	0	P
693-A	KBA - PERFORMA 574	54 x 74	870	34,25"	24	0,94"	3	0,12"	0	P
694	KBA		880	34,65"	35	1,38"	2	0,08"	0	P
695	KBA - RAPIDA 104 - СТАНДАРТНЫЙ - STANDARD	72 x 104	1130	44,49"	46	1,81"	0,5	0,02"	0	MR
700	KBA - RAPIDA 105 - СТАНДАРТНЫЙ - STANDARD	72 x 105	1140	44,88"	46	1,81"	0,5	0,02"	0	MR
702	KBA - RAPIDA 105 - Для УФ красок/For"UV"inks - Пластик/Plastic	72 x 105	1140	44,88"	53	2,09"	3	0,12"	0	P
703	KBA - RAPIDA 105 - Для УФ красок/For"UV"inks - TEFLON - Специальный/Special	72 x 105	1140	44,88"	53	2,09"	3	0,12"	0	T
701	KBA - RAPIDA 105 - NEW MODEL - СТАНДАРТНЫЙ - STANDARD	72 x 105	1160	45,67"	35	1,38"	2	0,08"	0	P
705	KBA - RAPIDA 104 - Специальный/Special - Старая модель/Old model	72 x 104	1130	44,49"	60	2,36"	0,5	0,02"	12	MR
710	KBA - R 104 Старая модель 1981/Old model 1981	72 x 102	1154	45,43"	46	1,81"	0,5	0,02"	11	MR
715	KBA - RAPIDA 130	91 x 130								
720	KBA - RAPIDA 130 - A	96,5 x 130								
725	KBA - RAPIDA 142 - СТАНДАРТНЫЙ - STANDARD	102 x 142	1510	59,45"	65	2,56"	0,5	0,02"	17	MR
726	KBA - RAPIDA 142 - Для УФ красок/For"UV"inks - Пластик/Plastic	102 x 142	1510	59,45"	70	2,76"	3	0,12"	17	P
727	KBA - RAPIDA 142 - Для УФ красок/For"UV"inks - TEFLON - Специальный/Special	102 x 142	1510	59,45"	70	2,76"	3	0,12"	17	T
730	KBA - RAPIDA 162/162 A - СТАНДАРТНЫЙ - STANDARD (PLAN 19)	112x162 20x162	1710	67,32"	64	2,52"	0,5	0,02"	19	MR
733	KBA - RAPIDA 185	129 x 185								
735	KBA - RAPIDA 205	149 x 205	2140	84,25"	60	2,36"	0,5	0,02"	30	MR

KBA - РУЛОННЫЙ ОФСЕТ - WEB OFFSET

КОД CODE	МОДЕЛЬ МАШИНЫ - MACHINE & MODEL	РАЗМЕР SIZE	A		B		C		D	E
			MM	INCHES	MM	INCHES	MM	INCHES		
740	KBA СОМПАСТА - 101 (PLAN 57)	РУЛ.ОФСЕТ	760	29,22"	45	1,77"	0,5	0,02"	10	MR
745	KBA СОМПАСТА - 106	РУЛ.ОФСЕТ								
755	KBA - S40 - S50	РУЛ.ОФСЕТ	1015	39,96"	68	2,68"	0,5	0,02"	8	MR
756	KBA СОМПАСТА 45	РУЛ.ОФСЕТ	1027	40,43"	70	2,76"	0,5	0,02"	8	MR
757	KBA СОМПАСТА 560	РУЛ.ОФСЕТ	1214	47,80"	70	2,76"	0,5	0,02"	8	MR
760	KBA СОМПАСТА 214	РУЛ.ОФСЕТ	1030	40,55"	48	1,89"	0,5	0,02"	11	MR
762	KBA СОМПАСТА - COMET (ФАЛЬЦОВКА - FOLDED)	РУЛ.ОФСЕТ	1060	41,73"	95	3,74"	0,5	0,02"	6	MR
765	KBA СОМПАСТА 215 - СТАНДАРТНЫЙ - STANDARD	РУЛ.ОФСЕТ	1092	42,99"	71	2,80"	0,5	0,02"	0	MR
766	KBA СОМПАСТА 216 (ФАЛЬЦОВКА - FOLDED)	РУЛ.ОФСЕТ	1092	42,99"	75	2,95"	0,5	0,02"	0	MR
770	KBA СОМПАСТА 216 (PLAN 87)	РУЛ.ОФСЕТ	1030	40,55"	70	2,76"	0,5	0,02"	7	MR
775	KBA СОМПАСТА 218	РУЛ.ОФСЕТ								
780	KBA СОМПАСТА 318	РУЛ.ОФСЕТ								
785	KBA СОМПАСТА 408	РУЛ.ОФСЕТ								
790	KBA СОМПАСТА 417 (PLAN 86)	РУЛ.ОФСЕТ	1030	40,55"	45	1,77"	0,5	0,02"	11	MR
795	KBA СОМПАСТА 418	РУЛ.ОФСЕТ								
800	KBA СОМПАСТА 618	РУЛ.ОФСЕТ	1515	59,65"	70	2,76"	0,5	0,02"	10	MR
805	KBA СОМПАСТА	РУЛ.ОФСЕТ	1516	59,69"	95	3,74"	0,5	0,02"	9	MR
806	KBA SUPER SIMUTION	РУЛ.ОФСЕТ	880	34,65"	32	1,26"	3	0,12"	0	V

KBA - ГАЗЕТНАЯ РОТАЦИЯ - WEB PRESS FOR NEWSPAPERS

КОД CODE	МОДЕЛЬ МАШИНЫ - MACHINE & MODEL	РАЗМЕР SIZE	A		B		C		D	E
			MM	INCHES	MM	INCHES	MM	INCHES		
810	KBA C 213 - (2/2)	РУЛ.ОФСЕТ								
815	KBA CONTINENTAL (2/2)	РУЛ.ОФСЕТ								
818	KBA СОМЕТ (PLAN 69)	РУЛ.ОФСЕТ	880	34,64"	70	2,76"	0,5	0,02"	0	MR
820	KBA СОМЕТ (4/2) (ФАЛЬЦОВКА - FOLDED)	РУЛ.ОФСЕТ	880	34,64"	72	2,83"	0,5	0,02"	0	MR
822	KBA СОМЕТ (PLAN 62)	РУЛ.ОФСЕТ	1000	39,37"	72	2,83"	0,5	0,02"	0	MR
825	KBA JOURNAL (PLAN 39)	РУЛ.ОФСЕТ	1440	56,69"	70	2,76"	0,5	0,02"	10	MR
716	KBA COLORA (PLAN 24)	РУЛ.ОФСЕТ	1310	51,57"	70	2,76"	0,5	0,02"	9	MR
829	KBA (PLAN 41)	РУЛ.ОФСЕТ	1320	51,97"	91	3,58"	0,5	0,02"	9	MR
830	KBA COLORA (PLAN 68)	РУЛ.ОФСЕТ	1320	51,97"	95	3,74"	0,5	0,02"	9	MR
832	KBA	РУЛ.ОФСЕТ	1325	52,17"	70	2,76"	0,5	0,02"	9	MR
835	KBA	РУЛ.ОФСЕТ	1332	52,44"	95	3,74"	0,5	0,02"	8	MR
837	KBA COMMANDER (PLAN 11)	РУЛ.ОФСЕТ	1440	56,69"	70	2,76"	0,5	0,02"	10	MR
840	KBA COMMANDER	РУЛ.ОФСЕТ	1549	60,98"	65	2,56"	0,5	0,02"	16	MR
845	KBA COMMANDER	РУЛ.ОФСЕТ	1640	64,57"	68	2,68"	0,5	0,02"	11	MR
846	KBA COMMANDER	РУЛ.ОФСЕТ	1720	67,71"	95	3,74"	0,5	0,02"	9	MR
852	KBA COMMANDER	РУЛ.ОФСЕТ	1640	64,75"	72	2,83"	0,5	0,02"	0	MR
848	KBA COMMANDER (ФАЛЬЦОВКА - FOLDED)	РУЛ.ОФСЕТ	1680	66,14"	72	2,83"	0,5	0,02"	0	MR
849	KBA COMMANDER - KBA COLORA (PLAN 45)	РУЛ.ОФСЕТ	1680	66,14"	70	2,76"	0,5	0,02"	0	MR
850	KBA COLORA (PLAN 47)	РУЛ.ОФСЕТ	1680	66,14"	72	2,83"	0,5	0,02"	0	MR
851	KBA COMMANDER (PLAN 46)	РУЛ.ОФСЕТ	1760	69,29"	72	2,83"	0,5	0,02"	0	MR
855	KBA (PLAN 42)	РУЛ.ОФСЕТ	1690	66,54"	70	2,76"	0,5	0,02"	11	MR
860	KBA COMMANDER (PLAN 67)	РУЛ.ОФСЕТ	1640	64,57"	95	3,74"	0,5	0,02"	9	MR
847	KBA COMMANDER	РУЛ.ОФСЕТ	1810	71,26"	70	2,76"	0,5	0,02"	9	MR
862	KBA (PLAN 63)	РУЛ.ОФСЕТ	1810	71,26"	70	2,76"	0,5	0,02"	10	MR

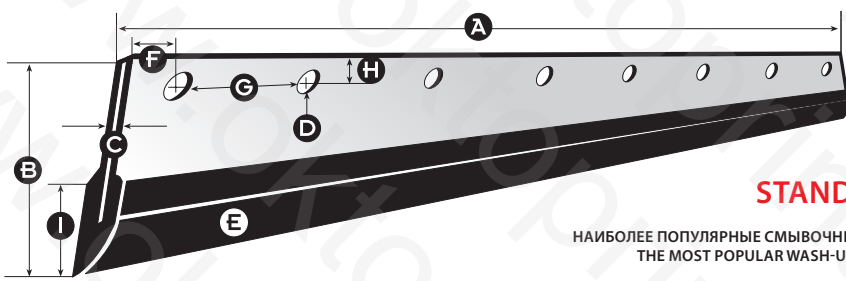

STANDARD

НАИБОЛЕЕ ПОПУЛЯРНЫЕ СМЫВОЧНЫЕ НОЖИ
THE MOST POPULAR WASH-UP BLADES

ВАЖНО: ПРИ ЗАКАЗЕ СМЫВОЧНЫХ НОЖЕЙ СО СПЕЦИАЛЬНОЙ EPDM-РЕЗИНОЙ ДЛЯ УФ-КРАСКИ ЦЕНА ВОЗРАСТАЕТ НА 15%
IMPORTANT: FOR ORDERS OF WASH-UP BLADES WITH THE SPECIAL "EPDM" RUBBER PROFILE FOR "UV" INK: 15% PRICE INCREASE

	ЛЕГЕНДА	КЕУ
A =	Длина	Length
B =	Ширина	Width
C =	Толщина	Thickness
D =	Количество отверстий	N° of holes
E =	Тип ножа	Blade type
M =	Металл	Metal
R =	Резина	Rubber
MR =	Металл + Резина	Metal + Rubber
F =	Ламинированная Фибра	Laminated Fibre
P =	Пластик	Plastic
T =	Тефлон	Teflon
V =	Вулколлан	Vulcollan

ПЛАНЕТА

КОД КОДЕ	МОДЕЛЬ МАШИНЫ - MACHINE & MODEL	РАЗМЕР SIZE	A		B		C		D	E
			MM	INCHES	MM	INCHES	MM	INCHES		
1150	ПЛАНЕТА 4 - E SUPER VARIANT "СТАНДАРТНЫЙ - STANDARD"	71 x 102	1060	41,73"	60	2,36"	5	0,20"	9	P
1155	ПЛАНЕТА VARIMAT Vulcollan	72 x 102	1130	44,49"	33	1,30"	5	0,20"	0	V
1160	ПЛАНЕТА 4 - E SUPER VARIANT "SPECIAL"	71 x 102	1060	41,73"	65	2,56"	0,5	0,02"	9	MR
1165	ПЛАНЕТА "SPECIAL"	72 x 102	1150	45,28"	65	2,56"	0,5	0,02"	13	MR
1166	ПЛАНЕТА - KBA - VL84		1148	45,20"	64	2,52"	0,5	0,02"	5	MR
1170	ПЛАНЕТА 6 "СТАНДАРТНЫЙ - STANDARD"	90x126/96x127	1350	53,15"	60	2,36"	5	0,20"	15	P
1172	ПЛАНЕТА/KBA V 126		1378	54,25"	60	2,36"	5	0,20"	15	P
1175	ПЛАНЕТА 7 "СТАНДАРТНЫЙ - STANDARD"	100 x 140	1510	59,45"	60	2,36"	5	0,20"	15	P
1177	ПЛАНЕТА VARIANT	100 x 140	1505	59,25"	80	3,15"	0,5	0,02"	16	MR
1180	ПЛАНЕТА 8 - 8/A "СТАНДАРТНЫЙ - STANDARD" - KBA - VARIMAT 95 -	112x162/120x162	1710	67,32"	60	2,36"	5	0,20"	17	P

КОМОРИ

КОД КОДЕ	МОДЕЛЬ МАШИНЫ - MACHINE & MODEL	РАЗМЕР SIZE	A		B		C		D	E
			MM	INCHES	MM	INCHES	MM	INCHES		
895	КОМОРИ (Гибкий/Flexible)		580	22,83"	47	1,85"	0,5	0,02"	8	MR
900	SPRINT 20 (Гибкий/Flexible)	36 x 52	590	23,23"	42	1,65"	0,5	0,02"	5	MR
905	LITHRONE 20 - LITHRONE 420 (Rigida/Rigid/Rigida)	36 x 52	590	23,23"	36	1,42"	2	0,08"	5	MR
907	LITHRONE SPRINT 26/226 - VARIANT - (Гибкий/Flexible)		706	27,80"	47	1,85"	0,5	0,02"	10	MR
908	LITHRONE 26 - A/W (NARROW)		700	27,56"	42	1,65"	0,5	0,02"	10	MR
910	SPRINT L 25 (Гибкий/Flexible)	46 x 65	710	27,95"	42	1,65"	0,5	0,02"	6	MR
911	SPRINT 25 - Vulcollan		710	27,95"	35	1,37"	5	0,20"	12	V
915	SPRINT 26 (Rigida/Rigid/Rigida)	46 x 65	715	28,15"	50	1,97"	2	0,08"	6	MR
915-A	КОМОРИ 26 SPRINT VARIANT	46 x 65	720	28,35"	50	1,97"	0,5	0,02"	8	MR
916	КОМОРИ - CHAMBON - (Пластик/Plastic)		725	28,54"	40	1,57"	1	0,04"	0	P
917	КОМОРИ - CHAMBON		725	28,54"	40	1,57"	0,5	0,02"	0	MR
918	КОМОРИ - SPICA 26 (Пластик/Plastic)		715	28,15"	37	1,46"	1	0,04"	10	P
919	КОМОРИ - SPICA 26		715	28,15"	37	1,46"	0,5	0,02"	10	MR
920	SPRINT 25 NEW TYPE (Гибкий/Flexible)		719	28,31"	45	1,77"	0,5	0,02"	6	MR
922	SPRINT 26	46 x 65	720	28,35"	43	1,62"	0,5	0,02"	8	MR
921	SPRINT (Гибкий/Flexible)	46 x 65	725	28,54"	50	1,97"	0,5	0,02"	0	MR
923	LITHRONE LS 26		730	28,74"	35	1,38"	1	0,04"	10	P
924	LITHRONE LS 26		730	28,74"	35	1,38"	0,5	0,02"	10	MR
925	LITHRONE 26 SPRINT (Rigida/Rigid/Rigida) СТАНДАРТНЫЙ - STANDARD	48 x 66	726	28,58"	36	1,42"	2	0,08"	6	MR
930	LITHRONE 26 (Гибкий/Flexible) СТАНДАРТНЫЙ - STANDARD	48 x 66	726	28,58"	37	1,46"	0,5	0,02"	6	MR
935	LITHRONE 26 - LITHRONE 526 (Гибкий/Flexible)	48 x 66	726	28,58"	42	1,65"	0,5	0,02"	6	MR
936	LITHRONE 26 - (Lavacaucchi/Autowash/Lavacauchos)		715	28,15"	42	1,65"	0,5	0,02"	10	MR
937	LITHRONE 26/426		730	28,74"	35	1,37"	1	0,04"	10	P
940	LITHRONE 28 SPRINT (Rigida/Rigid/Rigida) СТАНДАРТНЫЙ - STANDARD	52 x 72	785	30,91"	36	1,42"	2	0,08"	6	MR
945	LITHRONE 28 (Гибкий/Flexible)	52 x 72	785	30,91"	37	1,46"	0,5	0,02"	6	MR
946	LITHRONE 28/428/528 - (Пластик/Plastic)	52 x 72	785	30,91"	37	1,46"	5	0,20"	6	P
950	LITHRONE 28/(Гибкий/Flexible)	52 x 72	780	30,71"	42	1,65"	0,5	0,02"	9	MR
955	LITHRONE 428 (Пластик/Plastic)	52 x 72	765	30,12"	47	1,85"	5	0,20"	11	P
960	LITHRONE 28/ 528 (Гибкий/Flexible) СТАНДАРТНЫЙ - STANDARD	52 x 72	765	30,12"	47	1,85"	0,5	0,02"	11	MR
962	LITHRONE 528 (Гибкий/Flexible) СТАНДАРТНЫЙ - STANDARD	52 x 72	775	30,51"	47	1,85"	0,5	0,02"	11	MR
963	SPICA 29 - (Пластик/Plastic)	54 x 74	808	31,81"	38	1,50"	2	0,08"	11	P
961	SPICA 29 -	54 x 74	805	31,70"	48	1,89"	0,5	0,02"	11	MR
966	КОМОРИ LSX - 29/429 - 529 - 629 - 829	54 x 74	820	32,28"	35	1,38"	1	0,04"	11	P
972	КОМОРИ LITHRONE 32		892	35,12"	43	1,69"	5	0,20"	6	P
969	КОМОРИ 35 - SYSTEM		959	37,76"	49	1,93"	0,5	0,02"	13	MR
971	КОМОРИ 35 - SYSTEM B2		971	38,23"	50	1,97"	0,5	0,02"	13	MR
964	LITHRONE 40	72 x 103	1095	43,11"	52	2,05"	0,5	0,02"	8	MR
965	LITHRONE 40 (Пластик/Plastic)	72 x 103	1095	43,11"	50	1,97"	5	0,20"	8	P
967	LITHRONE 40 (Пластик/Plastic)	72 x 103	1095	43,11"	50	1,97"	5	0,20"	15	P
968	LITHRONE 40 (Acciaio + gomma/Metal + rubber/Acero + goma)	72 x 103	1095	43,11"	50	1,97"	0,5	0,02"	15	MR
970	LITHRONE 40 (Acciaio + gomma/Metal + rubber/Acero + goma)	72 x 103	1095	43,11"	50	1,97"	0,5	0,02"	8	MR
975	LITHRONE 40 (Пластик/Plastic)	72 x 103	1067	42,01"	47	1,85"	5	0,20"	15	P
980	LITHRONE 40 (Acciaio + gomma/Metal + rubber/Acero + goma)	72 x 103	1067	42,01"	47	1,85"	0,5	0,02"	15	MR
985	LITHRONE 40 (Acciaio + gomma/Metal + rubber/Acero + goma) СТАНДАРТНЫЙ - STANDARD	72 x 103	1090	42,91"	47	1,85"	0,5	0,02"	15	MR

КОМОРИ

КОД КОДЕ	МОДЕЛЬ МАШИНЫ - MACHINE & MODEL	РАЗМЕР SIZE	A		B		C		D	E
			MM	INCHES	MM	INCHES	MM	INCHES		
990	LITHRONE 40 (Металл+Резина/Metal+Rubber - Овальные отверстия/Oval holes)	72 x 103	1090	42,91"	47	1,85"	0,5	0,02"	15	MR
995	LITHRONE 40 (Металл+Резина/Metal+Rubber)	72 x 103	1076	42,36"	47	1,85"	0,5	0,02"	15	MR
1000	LITHRONE 40 (Пластик/Plastic)	72 x 103	1076	42,36"	47	1,85"	5	0,20"	15	P
1001	LITHRONE 40 (Пластик/Plastic)	72 x 103	1076	42,36"	42	1,65"	5	0,20"	15	P
1005	LITHRONE 40 (Металл+Резина/Metal+Rubber) СТАНДАРТНЫЙ - STANDARD	72 x 103	1110	43,70"	47	1,85"	0,5	0,02"	15	MR
1007	LITHRONE 40 (Пластик/Plastic)	72 x 103	1110	43,70"	47	1,85"	5	0,20"	15	P
1008	LITHRONE 540 Новая модель/New model (Пластик/Plastic) 2003 СТАНДАРТНЫЙ - STANDARD	72 x 104	1110	43,70"	47	1,85"	1	0,04"	15	P
1009	LITHRONE - LS 440 - 540 - 640 - 840 (Пластик/Plastic) СТАНДАРТНЫЙ - STANDARD	72 x 104	1105	43,50"	50	1,97"	1	0,04"	15	P
1010	LITHRONE 40 (Vulcollan)	72 x 103	1098	43,23"	52	2,05"	6	0,24"	15	V
1011	LITHRONE LS 440 - 540 - 640 - 840	72 x 104	1105	43,50"	50	1,97"	0,5	0,02"	15	MR
1015	LITHRONE 40 (Металл+Резина/Metal+Rubber)	72 x 103	1098	43,23"	52	2,05"	0,5	0,02"	15	MR
1017	LITHRONE 40 (Пластик/Plastic)	72 x 103	1098	43,23"	52	2,05"	5	0,20"	15	P
1018	LITHRONE 44 (Металл+Резина/Metal+Rubber)	74 x 104	1120	44,09"	52	2,05"	0,5	0,02"	15	MR
1019	LITHRONE 44 (Vulcollan)	82 x 113	1185	46,65"	45	1,77"	5	0,20"	17	V
1020	LITHRONE 44	82 x 113	1192	46,93"	50	1,97"	0,5	0,02"	17	MR
1021	LITHRONE 44 (Пластик/Plastic)	82 x 113	1192	46,93"	50	1,97"	5	0,20"	17	P
1022	LITHRONE 44 SP	82 x 116	1210	47,64"	47	1,85"	0,5	0,02"	17	MR
1023	LITHRONE 44	82 x 113	1190	46,89"	50	1,97"	0,5	0,02"	9	MR
1024	LITHRONE 44	82 x 116	1210	47,64"	47	1,85"	5	0,20"	17	P
1025	LITHRONE 50 (Пластик/Plastic)	96,5x128	1380	54,33"	50	1,97"	5	0,20"	10	P
1030	LITHRONE 50 (Металл+Резина/Metal+Rubber)	96,5x128	1380	54,33"	42	1,65"	0,5	0,02"	19	MR
1035	LITHRONE 50 (Пластик/Plastic)	96,5x128	1376	54,17"	50	1,97"	5	0,20"	19	P
1040	LITHRONE 50 (Металл+Резина/Metal+Rubber)	96,5x128	1379	54,29"	50	1,97"	0,5	0,02"	10	MR
1042	LITHRONE 50 (Пластик/Plastic)	96,5x128	1385	54,53"	50	1,97"	3	0,12"	19	P
1043	LITHRONE 50 (Металл+Резина/Metal+Rubber)	96,5x128	1380	54,33"	50	1,97"	0,5	0,02"	19	MR
1050	КОМОРИ SYSTEM 20	РУЛ.ОФСЕТ	590	23,33"	56	2,20"	0,5	0,02"	7	MR
1055	КОМОРИ SYSTEM 40	РУЛ.ОФСЕТ	1030	40,55"	47	1,85"	0,5	0,02"	11	MR
1060	КОМОРИ SYSTEM 35 (COD.969)	РУЛ.ОФСЕТ	959	37,76"	49	1,93"	0,5	0,02"	13	MR
1065	КОМОРИ SYSTEM 352/B2 (COD.971)	РУЛ.ОФСЕТ	971	38,23"	50	1,97"	0,5	0,02"	13	MR
1070	КОМОРИ SYSTEM 38	РУЛ.ОФСЕТ	1029	40,51"	47	1,85"	0,5	0,02"	11	MR
1071	КОМОРИ SYSTEM 38	РУЛ.ОФСЕТ	1040	40,94"	55	2,17"	0,5	0,02"	11	MR
1072	КОМОРИ SYSTEM 38	РУЛ.ОФСЕТ	1050	41,34"	50	1,97"	0,5	0,02"	11	MR

MITSUBISHI

КОД КОДЕ	МОДЕЛЬ МАШИНЫ - MACHINE & MODEL	РАЗМЕР SIZE	A		B		C		D	E
			MM	INCHES	MM	INCHES	MM	INCHES		
1235	MITSUBISHI - DAIYA 1F - ПЛАСТИК/PLASTIC		776	30,55"	28	1,10"	1	0,04"	9	P
1237	MITSUBISHI - DAIYA 1F		776	30,55"	28	1,10"	0,5	0,02"	9	MR
1240	MITSUBISHI 1E	52 x 72	780	30,71"	33	1,30"	0,5	0,02"	9	MR
1242	MITSUBISHI 1E TEFLON	52 x 72	780	30,71"	33	1,30"	5	0,20"	9	T
1243	MITSUBISHI 1F - DAIYA - IF - ТЕФЛОН/TEFLON	52 x 72	781	30,75"	40	1,57"	2	0,08"	8	T
1245	MITSUBISHI 1F - СТАНДАРТНЫЙ - STANDARD	52 x 72	785	30,91"	40	1,57"	0,5	0,02"	8	MR
1247	MITSUBISHI 1E ТЕФЛОН/TEFLON	52 x 72	785	30,91"	40	1,57"	5	0,20"	8	T
1248	MITSUBISHI/DIAMOND 2000		877	34,53"	33	1,30"	0,5	0,02"	10	MR
1246	MITSUBISHI/DIAMOND 2000		890	35,04"	35	1,38"	2	0,08"	13	P
1244	MITSUBISHI BT - 2800 - SSS		945	37,20"	60	2,36"	0,5	0,02"	10	MR
1249	MITSUBISHI 3F/DIAMOND 3000	74 x 104	1091	42,95"	40	1,57"	0,5	0,02"	11	MR
1250	MITSUBISHI 3F/DIAMOND 3000 - СТАНДАРТНЫЙ - STANDARD	74 x 104	1098	43,23"	40	1,57"	0,5	0,02"	11	MR
1251	MITSUBISHI 3F/DIAMOND	72 x 102	1080	42,52"	35	1,38"	0,5	0,02"	11	MR
1252	MITSUBISHI 3F	74 x 104	1088	42,83"	46	1,81"	3	0,12"	11	P
1253	MITSUBISHI 3F/DIAMOND 3000	74 x 104	1080	42,52"	50	1,97"	0,5	0,02"	11	MR
1254	MITSUBISHI 3F/DIAMOND ПЛАСТИК/PLASTIC	74 x 104	1090	42,91"	45	1,77"	3	0,12"	11	P
1261	MITSUBISHI DAIYA/3F - DIAMOND 3000 - ПЛАСТИК/PLASTIC	74 x 104	1086	42,76"	45	1,77"	3	0,12"	11	P
1255	MITSUBISHI 3F - СПЕЦИАЛЬНЫЙ ТЕФЛОН/TEFLON, SPECIAL TEFLON	74 x 104	1095	43,11"	43	1,69"	5	0,20"	11	T
1258	MITSUBISHI - AY - 700 - NEO	74 x 104	1100	43,31"	60	2,36"	0,5	0,02"	13	MR
1256	MITSUBISHI 4F	82 x 112	1186	46,69"	40	1,57"	0,5	0,02"	11	MR
1257	MITSUBISHI 4E	82 x 112	1190	46,85"	47	1,85"	0,5	0,02"	10	MR
1260	MITSUBISHI 5F - СТАНДАРТНЫЙ - STANDARD	92 x 132	1366	53,78"	40	1,57"	0,5	0,02"	13	MR
1266	MITSUBISHI DAIYA 5F - PLASTIC		1366	53,78"	40	1,57"	3	0,12"	13	P
1266-A	MITSUBISHI DAIYA 5F - VULCOLLAN	92 x 132	1366	53,78"	40	1,57"	5	0,20"	13	V
1262	MITSUBISHI DAIYA/- DIAMOND 5000	92 x 132	1410	55,51"	45	1,77"	2	0,08"	21	P
1263	MITSUBISHI DAIYA/- DIAMOND 5000 - ТЕФЛОН/TEFLON	92 x 132	1410	55,51"	45	1,77"	2	0,08"	21	T
1265	MITSUBISHI 6F	100 x 140	1506	59,29"	40	1,57"	0,5	0,02"	14	MR
1270	MITSUBISHI РУЛОННЫЙ ОФСЕТ - WEB PRESS	РУЛ.ОФСЕТ	1524	60,00"	60	2,36"	0,5	0,02"	16	MR
1275	MITSUBISHI L 750 РУЛОННЫЙ ОФСЕТ - WEB PRESS	РУЛ.ОФСЕТ	1050	41,34"	50	1,97"	0,5	0,02"	11	MR
1280	MITSUBISHI (PLAN 89)		1655	65,16"	65	2,56"	0,5	0,02"	18	MR

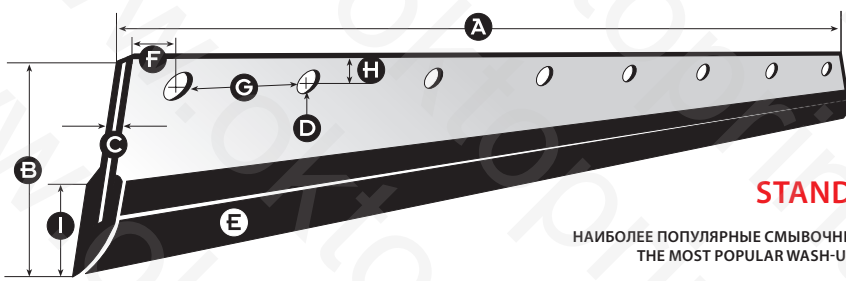

STANDARD

НАИБОЛЕЕ ПОПУЛЯРНЫЕ СМЫВОЧНЫЕ НОЖИ
THE MOST POPULAR WASH-UP BLADES

ВАЖНО: ПРИ ЗАКАЗЕ СМЫВОЧНЫХ НОЖЕЙ СО СПЕЦИАЛЬНОЙ EPDM-РЕЗИНОЙ ДЛЯ УФ-КРАСКИ ЦЕНА ВОЗРАСТАЕТ НА 15%
IMPORTANT: FOR ORDERS OF WASH-UP BLADES WITH THE SPECIAL "EPDM" RUBBER PROFILE FOR "UV" INK: 15% PRICE INCREASE

	ЛЕГЕНДА	КЕY
A =	Длина	Length
B =	Ширина	Width
C =	Толщина	Thickness
D =	Количество отверстий	N° of holes
E =	Тип ножа	Blade type
M =	Металл	Metal
R =	Резина	Rubber
MR =	Металл + Резина	Metal + Rubber
F =	Ламинированная Фибра	Laminated Fibre
P =	Пластик	Plastic
T =	Тефлон	Teflon
V =	Вулколлан	Vulcollan

AKIYAMA

КОД КОДЕ	МОДЕЛЬ МАШИНЫ - MACHINE & MODEL	РАЗМЕР SIZE	A		B		C		D	E
			MM	INCHES	MM	INCHES	MM	INCHES		
1329	AKIYAMA "BESTECH" 28 Новая модель/New model - Пластик/Plastic		790	31,10"	45	1,77"	1	0,04"	11	P
1330	AKIYAMA "BESTECH" 28	52 x 72	795	31,30"	45	1,77"	5	0,20"	11	R
1331	AKIYAMA "BESTECH" 28		804	31,65"	45	1,77"	5	0,20"	11	R
1332	AKIYAMA "BESTECH" 29		840	33,07"	45	1,77"	5	0,20"	12	R
1333	AKIYAMA "BESTECH" 32		920	36,22"	45	1,77"	5	0,20"	13	R
1335	AKIYAMA "BESTECH" 40	72 x 102	1126	44,33"	50	1,97"	5	0,20"	12	R
1336	AKIYAMA "BESTECH" 40 Новая модель/New model	74 x 104	1120	44,09"	45	1,77"	5	0,20"	12	R
1337	AKIYAMA "BESTECH" 40		1115	43,90"	60	2,36"	5	0,20"	12	R
1338	AKIYAMA "BESTECH" 440	74 x 104	1122	44,17"	70	2,76"	5	0,20"	12	R
1342	AKIYAMA "J PRINT" 44		1223	48,15"	45	1,77"	5	0,20"	13	R

SAKURAY

КОД КОДЕ	МОДЕЛЬ МАШИНЫ - MACHINE & MODEL	РАЗМЕР SIZE	A		B		C		D	E
			MM	INCHES	MM	INCHES	MM	INCHES		
1290	SAKURAY OLIVER 6	32 x 48	530	20,87"	50	1,97"	3	0,12"	7	R
1295	SAKURAY OLIVER 52 СТАНДАРТНЫЙ - STANDARD	36 x 52	566	22,28"	50	1,97"	3	0,12"	8	R
1300	SAKURAY OLIVER 58	44 x 58	621	24,45"	50	1,97"	3	0,12"	9	R
1305	SAKURAY OLIVER 252	44 x 58	621	24,45"	50	1,97"	3	0,12"	9	R
1307	SAKURAY OLIVER 66/E СТАНДАРТНЫЙ - STANDARD	46 x 66	712	28,03"	50	1,97"	3	0,12"	10	R
1310	SAKURAY OLIVER 66	46 x 66	730	28,74"	50	1,97"	3	0,12"	9	R
1312	SAKURAY OLIVER 466 SDP		762	30,00"	50	1,97"	3	0,12"	9	R
1315	SAKURAY OLIVER 72 СТАНДАРТНЫЙ - STANDARD	52 x 72	790	31,10"	50	1,97"	3	0,12"	10	R
1317	SAKURAY OLIVER 572	52 x 72	790	31,10"	43	1,69"	0,5	0,02"	10	MR
1318	SAKURAY OLIVER 474	54 x 74	804	31,65"	48	1,89"	3	0,12"	10	R
1319	SAKURAY OLIVER 474	54 x 74	810	31,89"	48	1,89"	3	0,12"	10	R
1320	SAKURAY - Нож для устройств автоматической установки форм/Blade for mounting plates		644	25,35"	25	0,98"	3	0,12"	8	R
1321	SAKURAY - Нож для устройств автоматической установки форм/Blade for mounting plates		704	27,72"	32	1,26"	3	0,12"	9	R
1322	SAKURAY 475 - 575		882	34,72"	50	1,97"	3	0,12"	11	R

RYOBI

КОД КОДЕ	МОДЕЛЬ МАШИНЫ - MACHINE & MODEL	РАЗМЕР SIZE	A		B		C		D	E
			MM	INCHES	MM	INCHES	MM	INCHES		
2320	RYOBI 2700/2800	25 x 35	305	12,01"	40	1,57"	5	0,20"	6	R
2325	RYOBI 3200/3203/3300/3302 - СТАНДАРТНЫЙ - STANDARD	34 x 45	355	13,98"	40	1,57"	5	0,20"	6	R
2326	RYOBI 3200/3203/3300/3302 - Vulcollan	34 x 45	360	14,17"	40	1,57"	5	0,20"	6	V
2330	RYOBI 3200 PFA	34 x 45	351	13,82"	26	1,02"	5	0,20"	6	R
2335	RYOBI 3202 MCS - II° elemento		353	13,90"	25	0,98"	5	0,20"	6	R
2336	RYOBI 3202 MCS - I° elemento		353	13,90"	40	1,57"	5	0,20"	6	R
2338	RYOBI 3304 - H	34 x 45	364	14,33"	40	1,57"	5	0,20"	6	R
2339	RYOBI (Vulcollan)		388	15,28"	25	0,98"	5	0,20"	7	V
2340	RYOBI 450 - R/MCS - RYOBI 4502 MCS - I°/II° elemento		453	17,83"	40	1,57"	5	0,20"	6	R
2345	RYOBI 480/500 N	32 x 46	507	19,96"	45	1,77"	5	0,20"	9	R
2350	RYOBI 480 K/500 K	32 x 46	508	20,00"	45	1,77"	5	0,20"	11	R
2352	RYOBI		513	20,20"	45	1,77"	5	0,20"	11	R
2355	RYOBI 480 - KANP (Для нумер.секции/Numbering unit)	32 x 46	524	20,63"	42	1,65"	0,5	0,02"	11	MR
2360	RYOBI 500 K	32 x 46	506	19,92"	45	1,77"	5	0,20"	11	R
2365	RYOBI 500 KNP (Для нумер.секции/Numbering unit)	32 x 46	510	20,08"	42	1,65"	0,5	0,02"	11	MR
2370	RYOBI 510	36 x 52	559	22,01"	30	1,18"	3	0,12"	9	R
2371	RYOBI (Vulcollan)		559	22,01"	25	0,98"	5	0,20"	9	V
2375	RYOBI 520/522/525 - СТАНДАРТНЫЙ - STANDARD	36 x 52	570	22,44"	25	0,98"	5	0,20"	9	R
2375A	RYOBI 520/522/525 (Vulcollan)	36 x 52	570	22,44"	25	0,98"	5	0,20"	9	V
2376	RYOBI 520/522/524 HE/525 (Vulcollan)	36 x 52	578	22,56"	25	0,98"	5	0,20"	9	V
2378	RYOBI 520/522/524 HE/525 (Пластик/Plastic)	36 x 52	578	22,56"	25	0,98"	5	0,20"	9	P
2377	RYOBI 522 - HX	36 x 52	570	22,44"	30	1,18"	5	0,20"	9	R
2380	RYOBI 520/522/524 - NP (Для нумер.секции/Numbering unit)	36 x 52	545	21,46"	47	1,85"	0,5	0,02"	6	MR
2385	RYOBI 530/560	40 x 57	602	23,70"	40	1,57"	5	0,20"	13	R
2390	RYOBI 640	48 x 66	735	28,94"	45	1,77"	5	0,20"	16	R
2391	RYOBI 662 H	48 x 66	765	30,12"	35	1,38"	5	0,20"	11	R
2392	RYOBI 680	48 x 66	756	29,80"	34	1,34"	5	0,20"	11	P
2395	RYOBI 750 - ТЕФЛОН/TEFLON	54 x 74	850	33,46"	34	1,34"	5	0,20"	12	T
2397	RYOBI 750 - VULLOLLAN	54 x 74	850	33,46"	34	1,34"	5	0,20"	12	V
2398	RYOBI 750 - Пластик/Plastic	54 x 74	850	33,46"	34	1,34"	5	0,20"	12	P

HAMADA

КОД КОДЕ	МОДЕЛЬ МАШИНЫ - MACHINE & MODEL	РАЗМЕР SIZE	A		B		C		D	E
			MM	INCHES	MM	INCHES	MM	INCHES		
1982	HAMADA - ZL 4911 - Z СТАНДАРТНЫЙ - STANDARD		540	21,26"	55	2,17"	0,5	0,02"	6	MR
1983	HAMADA - 65 - 4912		714	28,11"	55	2,17"	0,5	0,02"	7	MR
1984	HAMADA - SA - 4912		620	24,41"	55	2,17"	0,5	0,02"	7	MR
1985	HAMADA - ZK - 4911 - 3		610	24,02"	55	2,17"	0,5	0,02"	6	MR
1986	HAMADA - HSO - DU 34 - 2 СТАНДАРТНЫЙ - STANDARD		357	14,06"	34	1,34"	0,5	0,02"	5	MR
1987	HAMADA - HSO - 75 - СТАНДАРТНЫЙ - STANDARD		482	18,98"	40	1,57"	0,5	0,02"	13	MR
1988	HAMADA - HSO - 234 - 2 СТАНДАРТНЫЙ - STANDARD		372	14,65"	42	1,65"	0,5	0,02"	5	MR
1989	HAMADA - HSO - 75		491	19,33"	50	1,97"	0,5	0,02"	13	MR
1990	HAMADA - HSO - 75		482	18,98"	50	1,97"	0,5	0,02"	13	MR
1991	HAMADA - HSO - 48		514	20,24"	46	1,81"	0,5	0,02"	14	MR
1992	HAMADA		554	21,81"	40	1,57"	0,5	0,02"	15	MR
1993	HAMADA - HSO - 700 V		314	12,36"	37	1,46"	0,5	0,02"	8	MR
1994	HAMADA - HSO - 800/2		540	21,26"	49	1,93"	0,5	0,02"	14	MR
1995	HAMADA - PM - 066 - 4912		570	22,44"	55	2,17"	0,5	0,02"	6	MR
1996	HAMADA - HSO - 700 V - CP 07 - 02		335	13,19"	45	1,77"	5	0,20"	9	R
2000	HAMADA ALFA 52 - B52L (Резина/Rubber)	36 x 52	560	22,05"	45	1,77"	5	0,20"	9	R
2005	HAMADA BETA 52	36 x 52	540	21,26"	47	1,85"	0,5	0,02"	14	MR
2007	HAMADA ALFA 58		620	24,41"	50	1,97"	5	0,20"	9	R
2008	HAMADA ALFA 58		620	24,41"	60	2,36"	5	0,20"	9	R
2010	HAMADA 500 CDA (Резина/Rubber)	26 x 32	322	12,68"	45	1,77"	5	0,20"	9	R
2015	HAMADA ALFA 66 (Резина/Rubber)	46 x 64	710	27,95"	50	1,97"	5	0,20"	11	R
2020	HAMADA STAR 700 DX SPECIAL	32 x 46	485	19,09"	47	1,85"	0,5	0,02"	11	MR
2025	HAMADA STAR 700 CDX/CDX/NP СТАНДАРТНЫЙ - STANDARD	32 x 46	480	18,90"	50	1,97"	0,5	0,02"	13	MR
2030	HAMADA STAR 700 CDX/CDX/NP (Резина/Rubber)	32 x 46	480	18,90"	40	1,57"	5	0,20"	13	R
2032	HAMADA 770 CDX - NP Для нумер.секции/Numbering unit		490	19,29"	50	1,97"	0,5	0,02"	13	MR
2035	HAMADA STAR 800 CDX (Резина/Rubber)	36 x 52	544	21,42"	45	1,77"	5	0,20"	14	R
2038	HAMADA 900 CD	40 x 58	630	24,80"	45	1,77"	5	0,20"	17	R
2040	HAMADA 52/02	36 x 52	555	21,85"	43	1,69"	0,5	0,02"	15	MR
2045	HAMADA 770 DX (Резина/Rubber)	36 x 52	488	19,21"	40	1,57"	5	0,20"	10	R
2047	HAMADA B 52	36 x 52								
2048	HAMADA H 234 A	34 x 45	373	14,69"	42	1,65"	0,5	0,02"	5	MR
2049	HAMADA H 234	34 x 45	358	14,10"	42	1,65"	5	0,20"	5	R
2051	HAMADA C52/C 252	36 x 52	554	21,81"	40	1,57"	0,5	0,02"	15	MR
2053	HAMADA B 452 - B 252 A - СТАНДАРТНЫЙ - STANDARD	36,5x 52	570	22,44"	40	1,57"	0,5	0,02"	15	MR
2054	HAMADA KRAMPUS 52 - R - 209 - 252		560	22,05"	45	1,77"	5	0,20"	9	R
2055	HAMADA VS SR34 - СТАНДАРТНЫЙ - STANDARD	26 x 32	357	14,06"	42	1,65"	0,5	0,02"	5	MR
2056	HAMADA STAR HSO - 60		322	12,68"	45	1,77"	5	0,20"	9	R
2057	HAMADA STAR HSO - 75		487	19,17"	45	1,77"	5	0,20"	13	R
2058	HAMADA STAR HSO - 700 V		335	13,19"	45	1,77"	5	0,20"	9	R
2059	HAMADA KRAMPUS - 58 R		620	24,41"	60	2,36"	5	0,20"	9	R

SHINOHARA/FUJI

КОД КОДЕ	МОДЕЛЬ МАШИНЫ - MACHINE & MODEL	РАЗМЕР SIZE	A		B		C		D	E
			MM	INCHES	MM	INCHES	MM	INCHES		
1085	SHINOHARA 271 - TS -		322	12,68"	42	1,65"	2	0,08"	5	MR
1090	FUJI 50	35 x 50	550	21,65"	47	1,85"	2	0,08"	8	MR
1095	FUJI 52 (Старая модель/Old model) - 2 мм. СТАНДАРТНЫЙ - STANDARD	36 x 52	580	22,83"	42	1,65"	2	0,08"	8	MR
1096	FUJI 52 (Старая модель/Old model) - 0,5 мм.	36 x 52	580	22,83"	42	1,65"	0,5	0,02"	8	MR
1100	FUJI 52 (Для нумер.секции/Numbering unit)	36 x 52	497	19,57"	26	1,02"	0,2	0,008"	0	M
1104	SHINOHARA FUJI 52 (Новая модель/New model) SPECIAL	36 x 52	550	21,65"	40	1,57"	2	0,08"	7	MR
1105	SHINOHARA 52 - СТАНДАРТНЫЙ - STANDARD (Новая модель/New model) - 2 мм.	36 x 52	550	21,65"	42	1,65"	2	0,08"	7	MR
1106	SHINOHARA 52 - (Новая модель/New model) - 0,5 мм.	36 x 52	550	21,65"	42	1,65"	0,5	0,02"	7	MR
1107	SHINOHARA 52 - (Для нумер.секции/Numbering unit)	36 x 52	500	19,69"	42	1,65"	0,5	0,02"	9	MR
1108	SHINOHARA 52 - (Новая модель/New model) 9 отверстий/9 holes	36 x 52	550	21,65"	42	1,65"	0,5	0,02"	9	MR
1109	FUJI BUSINESS FORM OFFSET PRESS		550	21,65"	49	1,93"	2	0,08"	8	MR
1110	FUJI SHINOHARA 56 (Новый/New)	44 x 58	610	24,02"	42	1,65"	2	0,08"	10	MR
1115	FUJI SHINOHARA 58	44 x 58	620	24,41"	47	1,85"	2	0,08"	9	MR
1120	FUJI SHINOHARA 65/66 СТАНДАРТНЫЙ - STANDARD	48 x 66	700	27,56"	47	1,85"	2	0,08"	11	MR
1122	SHINOHARA 75	52 x 74	780	30,71"	30	1,18"	1	0,04"	10	P
1125	FUJI SHINOHARA 74 СТАНДАРТНЫЙ - STANDARD	52 x 74	795	31,30"	47	1,85"	2	0,08"	13	MR
1130	SHINOHARA 102 - СТАНДАРТНЫЙ - STANDARD	72 x 104	1085	42,72"	47	1,85"	2	0,08"	17	MR
1135	FUJI SHINOHARA 74 Гибкий/Flexible СТАНДАРТНЫЙ - STANDARD	52 x 74	796	31,34"	47	1,85"	0,5	0,02"	13	MR

HASHIMOTO

КОД КОДЕ	МОДЕЛЬ МАШИНЫ - MACHINE & MODEL	РАЗМЕР SIZE	A		B		C		D	E
			MM	INCHES	MM	INCHES	MM	INCHES		
1790	HASHIMOTO AF - K.M.S.	36 x 52	539	21,22"	56	2,20"	0,5	0,02"	6	MR
1795	HASHIMOTO AF - S/AF - K	36 x 52	552	21,73"	56	2,20"	0,5	0,02"	6	MR
1800	HASHIMOTO F 521	36 x 52	570	22,44"	56	2,20"	0,5	0,02"	6	MR
1805	HASHIMOTO IMPULSE 20/F 522	36 x 52	570	22,44"	56	2,20"	0,5	0,02"	6	MR
1807	HASHIMOTO 525		620	24,40"	56	2,20"	0,5	0,02"	7	MR
1808	HASHIMOTO F56 IMPULSE		620	24,40"	55	2,16"	0,5	0,02"	6	MR
1810	HASHIMOTO 652 P	46 x 68	720	28,35"	56	2,20"	0,5	0,02"	7	MR
1812	HASHIMOTO IMPULSE 26 (ФАЛЬЦОВКА - FOLDED)	46 x 68	740	29,13"	58	2,28"	0,5	0,02"	7	MR
1814	HASHIMOTO IMPULSE 26	46 x 68	740	29,13"	56	2,20"	0,5	0,02"	7	MR

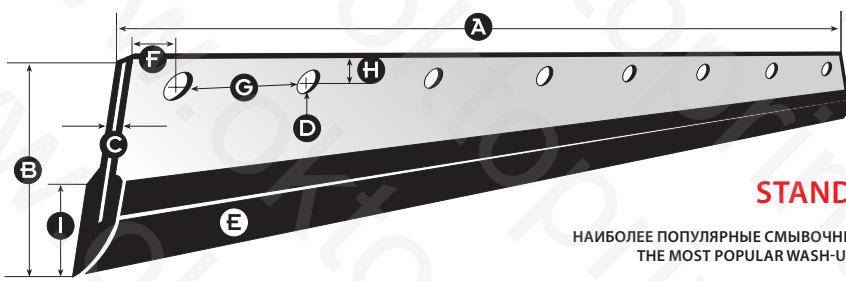

STANDARD

НАИБОЛЕЕ ПОПУЛЯРНЫЕ СМЫВОЧНЫЕ НОЖИ
THE MOST POPULAR WASH-UP BLADES

ВАЖНО: ПРИ ЗАКАЗЕ СМЫВОЧНЫХ НОЖЕЙ СО СПЕЦИАЛЬНОЙ EPDM-РЕЗИНОЙ ДЛЯ УФ-КРАСКИ ЦЕНА ВОЗРАСТАЕТ НА 15%
IMPORTANT: FOR ORDERS OF WASH-UP BLADES WITH THE SPECIAL "EPDM" RUBBER PROFILE FOR "UV" INK: 15% PRICE INCREASE

	ЛЕГЕНДА	КЕY
A =	Длина	Length
B =	Ширина	Width
C =	Толщина	Thickness
D =	Количество отверстий	N° of holes
E =	Тип ножа	Blade type
M =	Металл	Metal
R =	Резина	Rubber
MR =	Металл + Резина	Metal + Rubber
F =	Ламинированная Фибра	Laminated Fibre
P =	Пластик	Plastic
T =	Тефлон	Teflon
V =	Вулколан	Vulcollan

MILLER

КОД КОДЕ	МОДЕЛЬ МАШИНЫ - MACHINE & MODEL	РАЗМЕР SIZE	A		B		C		D	E
			MM	INCHES	MM	INCHES	MM	INCHES		
1200	MILLER TP 74 - TP 29	52 x 74	820	32,28"	68	2,68"	05	0,02"	8	MR
1205	MILLER TP 92 - TP 32	61 x 82	920	36,22"	68	2,68"	05	0,02"	9	MR
1210	MILLER TP 94 - TP 36	65 x 94	1020	40,16"	68	2,68"	05	0,02"	10	MR
1215	MILLER TP 38	65 x 97,5	1092	42,99"	78	3,07"	05	0,02"	11	MR
1216	MILLER TP 38S	72 x 102	1080	42,52"	70	2,76"	05	0,02"	10	MR
1220	MILLER TP 104 - 41S	72 x 104	1140	44,88"	68	2,68"	05	0,02"	12	MR

ALBERT FRANKENTAL

КОД КОДЕ	МОДЕЛЬ МАШИНЫ - MACHINE & MODEL	РАЗМЕР SIZE	A		B		C		D	E
			MM	INCHES	MM	INCHES	MM	INCHES		
870	ALBERT (Высокая печать/Турographic)	70 x 100	1030	40,55"	46	1,81"	0,5	0,02"	11	MR
875	КВА/ALBERT - 100	РУЛ.ОФСЕТ	1045	41,14"	64	2,52"	0,5	0,02"	11	MR
880	КВА/ALBERT - 200	РУЛ.ОФСЕТ	1080	42,52"	48	1,89"	0,5	0,02"	11	MR

MIEHLE

КОД КОДЕ	МОДЕЛЬ МАШИНЫ - MACHINE & MODEL	РАЗМЕР SIZE	A		B		C		D	E
			MM	INCHES	MM	INCHES	MM	INCHES		
640	MIEHLE	140 x 200	2000	78,74"	68	2,68"	0,5	0,02"	0	MR
645	MIEHLE - 77"	140 x 200	2077	81,77"	57	2,24"	0,5	0,02"	22	MR
648	MIEHLE	140 x 200	2058	81,02"	90	3,54"	0,5	0,02"	22	MR

HARRIS - РУЛОННЫЙ ОФСЕТ - WEB OFFSET

КОД КОДЕ	МОДЕЛЬ МАШИНЫ - MACHINE & MODEL	РАЗМЕР SIZE	A		B		C		D	E
			MM	INCHES	MM	INCHES	MM	INCHES		
1430	HARRIS 24 ROTOOFFSET 990	РУЛ.ОФСЕТ	552	21,73"	53	2,09"	0,5	0,02"	6	MR
1435	HARRIS 1200	РУЛ.ОФСЕТ	590	23,23"	58	2,28"	0,5	0,02"	7	MR
1437	HARRIS 1220	РУЛ.ОФСЕТ	603	23,74"	51	2,00"	0,5	0,02"	7	MR
1440	HARRIS M 110	РУЛ.ОФСЕТ	749	29,49"	68	2,68"	0,5	0,02"	8	MR
1445	HARRIS	РУЛ.ОФСЕТ	997	39,25"	65	2,56"	0,5	0,02"	11	MR
1446	HARRIS M 1000 (Пластик/Plastic)	РУЛ.ОФСЕТ	998	39,29"	90	3,54"	1	0,04"	7	P
1447	HARRIS 1000	РУЛ.ОФСЕТ	1054	41,50"	50	1,97"	0,5	0,02"	11	MR
1450	HARRIS 200 (Лицо - In bianca)	РУЛ.ОФСЕТ	1065	41,93"	60	2,36"	0,5	0,02"	11	MR
1455	HARRIS 200 (Оборот - In volta)	РУЛ.ОФСЕТ	1065	41,93"	78	3,07"	0,5	0,02"	11	MR
1460	HARRIS 1000 (Лицо - In bianca) M 200 - M 300	РУЛ.ОФСЕТ	1043	41,06"	65	2,56"	0,5	0,02"	11	MR
1465	HARRIS 1000 (Оборот - In volta)	РУЛ.ОФСЕТ	1043	41,06"	103	4,06"	0,5	0,02"	11	MR
1467	HARRIS 1000	РУЛ.ОФСЕТ	1065	41,93"	90	3,54"	0,5	0,02"	11	MR
1470	HARRIS M 1000	РУЛ.ОФСЕТ	1062	41,81"	98	3,86"	0,5	0,02"	11	MR
1475	HARRIS M 300 (Верхний и нижний рагель/Upper and lower)	РУЛ.ОФСЕТ	1043	41,06"	65	2,56"	0,5	0,02"	11	MR
1477	HARRIS/HEIDELBERG - 850		1044	41,10"	84	3,31"	0,5	0,02"	11	MR
1480	HARRIS M 850	РУЛ.ОФСЕТ	1064	41,89"	38	1,50"	0,5	0,02"	11	MR
1485	HARRIS M 850	РУЛ.ОФСЕТ	1064	41,89"	60	2,36"	0,5	0,02"	11	MR
1490	HARRIS M 850	РУЛ.ОФСЕТ	1064	41,89"	88	3,46"	0,5	0,02"	11	MR
1495	HARRIS MERCURY	РУЛ.ОФСЕТ	1036	40,79"	52	2,05"	0,5	0,02"	9	MR
1496	HARRIS		1036	40,79"	50	1,97"	2	0,08"	12	MR
1494	HARRIS - M 600 (PLAN81)		1150	45,28"	60	2,36"	0,5	0,02"	10	MR
1497	HARRIS 946	РУЛ.ОФСЕТ	1225	48,23"	90	3,54"	0,5	0,02"	13	MR
1498	HARRIS HEIDELBERG	РУЛ.ОФСЕТ	1348	53,07"	90	3,54"	0,5	0,02"	14	MR
1499	HARRIS - M 5000	РУЛ.ОФСЕТ	1353	53,27"	90	3,54"	0,5	0,02"	15	MR
1501	HARRIS - (PLAN 49)		1464	57,64"	50	1,97"	0,5	0,02"	13	MR
1500	HARRIS M 850 L	РУЛ.ОФСЕТ	1540	60,63"	78	3,07"	0,5	0,02"	17	MR
1505	HARRIS M 850 L (Верхний рагель/Upper grinding)	РУЛ.ОФСЕТ	1540	60,63"	64	2,52"	0,5	0,02"	17	MR
1510	HARRIS M 850 L (Нижний рагель/Lower Grinding)	РУЛ.ОФСЕТ	1540	60,63"	88	3,46"	0,5	0,02"	17	MR
1511	HARRIS - ULTRAMAN		1593	62,72"	65	2,56"	0,5	0,02"	17	MR
1512	HARRIS SUNDAY	РУЛ.ОФСЕТ	1580	62,20"	60	2,36"	0,5	0,02"	17	MR
1513	HARRIS SUNDAY	РУЛ.ОФСЕТ	1750	68,90"	60	2,36"	0,5	0,02"	19	MR
1514	HARRIS SUNDAY	РУЛ.ОФСЕТ	1755	69,09"	75	2,95"	0,5	0,02"	19	MR
1515	HARRIS 1650	РУЛ.ОФСЕТ	1815	71,46"	98	3,86"	0,5	0,02"	19	MR
1516	HARRIS "N 1700"	РУЛ.ОФСЕТ	1722	67,80"	64	2,52"	0,5	0,02"	18	MR
1517	HARRIS "N 1700"	РУЛ.ОФСЕТ	1665	65,55"	90	3,54"	0,5	0,02"	18	MR
1518	HARRIS "M 300"	РУЛ.ОФСЕТ	1466	57,72"	50	1,97"	0,5	0,02"	13	MR
1519	HARRIS SUNDAY - M 4000 - 64 Страницы/64 Pages	РУЛ.ОФСЕТ	2035	80,12"	60	2,36"	0,5	0,02"	22	MR

SOLNA INTERNATIONAL

КОД КОДЕ	МОДЕЛЬ МАШИНЫ - MACHINE & MODEL	РАЗМЕР SIZE	A		B		C		D	E
			MM	INCHES	MM	INCHES	MM	INCHES		
1660	SOLNA 54		565	22,24"	20	0,79"	5	0,20"	0	R
1665	SOLNA 24 SERIES		695	27,36"	52	2,05"	2	0,08"	9	T
1670	SOLNA 125/225	46 x 65	700	27,56"	22	0,87"	1	0,04"	0	P
1675	SOLNA 25/64 - 25 SERIES	46 x 65	730	28,74"	20	0,79"	1	0,04"	0	P
1676	SOLNA 25 (Резина/Rubber)		730	28,74"	20	0,79"	5	0,20"	0	R
1680	SOLNA 72	52 x 72	810	31,89"	22	0,87"	3	0,12"	0	R
1685	SOLNA 240	РУЛ.ОФСЕТ	1160	45,67"	20	0,79"	5	0,20"	0	R
1690	SOLNA RP 36	РУЛ.ОФСЕТ	1014	39,92"	45	1,77"	3	0,12"	14	R
1695	SOLNA DISTRIBUTOR	РУЛ.ОФСЕТ	1088	42,83"	45	1,77"	3	0,12"	15	R
1700	SOLNA D 22	РУЛ.ОФСЕТ								
1705	SOLNA D 25	РУЛ.ОФСЕТ								
1710	COMERCIAL (Рулонный офсет/Web offset)	16 Page/16 Pages								
1715	SOLNA 800 (Рулонный офсет/Web offset)	32 Page/32 Pages								
1720	SOLNA D 300 (Рулонный офсет/Web offset)									

MAILÄNDER ПЕЧАТЬ ПО ЖЕСТИ - TIN LITHOGRAPHIC PRESSES

КОД КОДЕ	МОДЕЛЬ МАШИНЫ - MACHINE & MODEL	РАЗМЕР SIZE	A		B		C		D	E
			MM	INCHES	MM	INCHES	MM	INCHES		
1885	MAILÄNDER		1226	48,27"	65	2,56"	0,5	0,02"	12	MR
1890	MAILÄNDER mod. 122/160/162		1250	49,21"	78	3,07"	0,5	0,02"	12	MR
1891	MAILÄNDER mod. 162		1267	49,88"	80	3,15"	6	0,24"	12	P
1891-A	MAILÄNDER mod. 162 - Vulcollan		1267	49,88"	73	2,87"	5	0,20"	12	V
1892	MAILÄNDER mod. 122 SPECIAL		1260	49,61"	81	3,19"	0,5	0,02"	12	MR
1895	MAILÄNDER mod. 122 SPECIAL		1250	49,21"	78	3,07"	0,5	0,02"	25	MR
1897	MAILÄNDER		1259	49,57"	48	1,89"	5	0,20"	12	P
1900	MAILÄNDER		1310	51,57"	110	4,33"	2	0,08"	12	MR
1905	MAILÄNDER - ПРОБОПЕЧАТНЫЙ СТАНОК/PROOFING PRESSES		1072	42,20"	45	1,77"	3	0,12"	11	P
1907	MAILÄNDER		1223	48,15"	144	5,67"	6	0,24"	13	P
1909	MAILÄNDER		1410	55,51"	60	2,36"	5	0,20"	14	P

CRABTREE LITOLATTA - TIN LITHOGRAPHIC PRESSES - METALGRAFICA

КОД КОДЕ	МОДЕЛЬ МАШИНЫ - MACHINE & MODEL	РАЗМЕР SIZE	A		B		C		D	E
			MM	INCHES	MM	INCHES	MM	INCHES		
1920	CRABTREE 40		1100	43,31"	154	6,06"	6	0,24"	12	P
1923	CRABTREE		1212	47,72"	49	1,93"	5	0,20"	9	P
1925	CRABTREE 45		1220	48,03"	154	6,06"	6	0,24"	13	P
1930	CRABTREE 1290 PRESS		1343	52,87"	40	1,57"	5	0,20"	19	P
1931	CRABTREE 1290 PRESS		1343	52,87"	40	1,57"	0,5	0,02"	19	MR

FUJI PRIMEX LITOLATTA - TIN LITHOGRAPHIC PRESSES - METALGRAFICA

КОД КОДЕ	МОДЕЛЬ МАШИНЫ - MACHINE & MODEL	РАЗМЕР SIZE	A		B		C		D	E
			MM	INCHES	MM	INCHES	MM	INCHES		
1910	FUJI PRIMEX 40		1140	43,86"	64	2,52"	0,5	0,02"	12	MR
1915	FUJI PRIMEX 45 - F 450		1250	49,21"	64	2,52"	0,5	0,02"	13	MR
1916	FUJI PRIMEX 445		1250	49,21"	64	2,52"	0,5	0,02"	0	MR
1917	FUJI PRIMEX		1250	49,21"	64	2,52"	0,5	0,02"	10	MR
1918	FUJI PRIMEX		1250	49,21"	64	2,52"	0,5	0,02"	9	MR

HANTSHO

КОД КОДЕ	МОДЕЛЬ МАШИНЫ - MACHINE & MODEL	РАЗМЕР SIZE	A		B		C		D	E
			MM	INCHES	MM	INCHES	MM	INCHES		
1950	HANTSHO	72 x 102	1054	41,50"	53	2,09"	0,5	0,02"	11	MR
1952	HANTSHO		930	36,61"	52	2,05"	0,5	0,02"	10	MR

DAVIDSON

КОД КОДЕ	МОДЕЛЬ МАШИНЫ - MACHINE & MODEL	РАЗМЕР SIZE	A		B		C		D	E
			MM	INCHES	MM	INCHES	MM	INCHES		
1970	DAVIDSON 500 - 501 - 502 P	25 x 35	302	11,89"	60	2,36"	0,5	0,02"	4	MR
1975	DAVIDSON 700 - 701 - 702 P	38 x 46	470	18,50"	60	2,36"	0,5	0,02"	5	MR
1980	DAVIDSON 900 - 901 - 902 P	36 x 52	530	20,87"	60	2,36"	0,5	0,02"	6	MR

ADAST/DOMINANT/ADAMOVSKЕ STROJIRNY

КОД КОДЕ	МОДЕЛЬ МАШИНЫ - MACHINE & MODEL	РАЗМЕР SIZE	A		B		C		D	E
			MM	INCHES	MM	INCHES	MM	INCHES		
2060	GRAFOPRESS PLATINA/PLATEN - GPE/GPA/GPC	26 x 38	380	14,96"	20	0,79"	5	0,20"	7	R
2065	DOMINANT 414	26 x 38	300	11,81"	25	0,98"	3	0,12"	8	R
2070	DOMINANT 313/314 - СТАНДАРТНЫЙ - STANDARD	36 x 52	542	21,34"	29	1,14"	3	0,12"	14	R
2075	DOMINANT 513	36 x 52	570	22,44"	33	1,30"	3	0,12"	15	R
2080	DOMINANT 514 - 515 - 524 - 525 - СТАНДАРТНЫЙ - STANDARD	36 x 52	542	21,34"	24	0,94"	3	0,12"	14	R
2085	DOMINANT 525	36 x 52	542	21,34"	30	1,18"	3	0,12"	14	R
2090	DOMINANT 516 - 526/B	36 x 52	557	21,93"	23	0,91"	3	0,12"	14	R
2095	DOMINANT 516 - 526 (Для нумер.секции/Numbering unit)	38 x 52	560	22,05"	21	0,83"	3	0,12"	16	R
2100	DOMINANT 712	44 x 58	630	24,80"	38	1,50"	3	0,12"	16	R
2105	DOMINANT 714 - 724 - 715 - 725 - 745 - 746 - СТАНДАРТНЫЙ - STANDARD	48,5x 66	665	26,18"	29,5	1,16"	3	0,12"	17	R
2110	DOMINANT 547 - P	38 x 52	555	21,85"	26	1,02"	3	0,12"	14	R
2115	DOMINANT 745 - P	48,5x 66	650	25,59"	26	1,02"	3	0,12"	18	R
2117	DOMINANT 747		670	26,38"	40	1,57"	0,5	0,02"	7	MR
2120	DOMINANT 755 - CP/756 AP	48,5x 66								
2122	DOMINANT 826 - P	52 x 74	772	30,39"	40	1,57"	3	0,12"	19	R
2125	DOMINANT 846 PA	52 x 74	780	30,70"	40	1,57"	3	0,12"	19	R
2130	DOMINANT 856 AP/826 AP	52 x 74								

MULTILITH

КОД КОДЕ	МОДЕЛЬ МАШИНЫ - MACHINE & MODEL	РАЗМЕР SIZE	A		B		C		D	E
			MM	INCHES	MM	INCHES	MM	INCHES		
2150	MULTILITH 1250 (Резина/Rubber)	26 x 38	266	10,47"	25	0,98"	3	0,12"	0	R
2155	MULTILITH 1650 (Резина/Rubber)	26 x 38	332	13,07"	25	0,98"	3	0,12"	0	R
2160	MULTILITH 1650 (Пластик/Plastic)	26 x 38	332	13,07"	25	0,98"	3	0,12"	0	P
2165	MULTILITH 1850 (Резина/Rubber)	32 x 46	485	19,09"	19	0,75"	3	0,12"	0	R
2170	MULTILITH 1860 (Резина/Rubber)	32 x 46	493	19,41"	20	0,79"	5	0,20"	0	R
2175	MULTILITH 1250)	26 x 38	274	10,79"	48	1,89"	0,5	0,02"	5	MR

AB DICK

КОД КОДЕ	МОДЕЛЬ МАШИНЫ - MACHINE & MODEL	РАЗМЕР SIZE	A		B		C		D	E
			MM	INCHES	MM	INCHES	MM	INCHES		
2190	AB - DICK 320/350/360	26 x 38	300	11,81"	22	0,87"	3	0,12"	0	R
2195	AB - DICK 910	26 x 38	328	12,91"	35	1,38"	3	0,12"	4	R
2200	AB - DICK 375/9810	26 x 38	338	13,31"	52	2,05"	3	0,12"	6	R
2205	AB - DICK 375	26 x 38	340	13,39"	50	1,97"	5	0,20"	6	R
2210	AB - DICK 380	40 x 57	582	22,91"	25	0,98"	3	0,12"	16	P

GESTETNER

КОД КОДЕ	МОДЕЛЬ МАШИНЫ - MACHINE & MODEL	РАЗМЕР SIZE	A		B		C		D	E
			MM	INCHES	MM	INCHES	MM	INCHES		
2280	GESTETNER 211/311 (Резина/Rubber)	25 x 35	260	10,24"	37	1,46"	3	0,12"	4	R
2285	GESTETNER 210/211/311/410/411/413 (Фибра/Fibre)	25 x 35	260	10,24"	37	1,46"	1	0,04"	4	F
2290	GESTETNER 410/411 (Резина/Rubber)	25 x 35	259	10,20"	40	1,57"	3	0,12"	4	R
2295	GESTETNER 213/313/413 (Ламинированная фибра/Laminated fibre)	25 x 35	350	13,78"	37	1,46"	1	0,04"	4	F
2300	GESTETNER 1250 (Резина/Rubber)	25 x 35	285	11,22"	20	0,79"	3	0,12"	5	R

ROTATEK - БЕСКОНЕЧНЫЕ ФОРМУЛЯРЫ/CONTINUOUS FORM

КОД КОДЕ	МОДЕЛЬ МАШИНЫ - MACHINE & MODEL	РАЗМЕР SIZE	A		B		C		D	E
			MM	INCHES	MM	INCHES	MM	INCHES		
2410	ROTATEK RK 100		410	16,14"	40	1,57"	5	0,20"	5	R
2415	ROTATEK MP 150 (Miniprint) - СТАНДАРТНЫЙ - STANDARD		442	17,40"	58	2,28"	0,5	0,02"	5	MR
2416	ROTATEK RK 180 - СТАНДАРТНЫЙ - STANDARD		492	19,37"	60	2,36"	0,5	0,02"	5	MR
2417	ROTATEK RK 190		470	18,50"	65	2,56"	0,5	0,02"	5	MR
2420	ROTATEK 100 - 200 - RK 200 PLUS - СТАНДАРТНЫЙ - STANDARD		537	21,14"	57	2,24"	0,5	0,02"	6	MR
2425	ROTATEK 300 ROTATEK 400		580	22,83"	57	2,24"	0,5	0,02"	6	MR
2430	ROTATEK 300 ROTATEK 400 SPECIAL (ОВАЛЬНЫЙ - OVAL)		580	22,83"	57	2,24"	0,5	0,02"	6	MR
2432	ROTATEK 300 ROTATEK 400		580	22,83"	50	1,97"	0,5	0,02"	6	MR

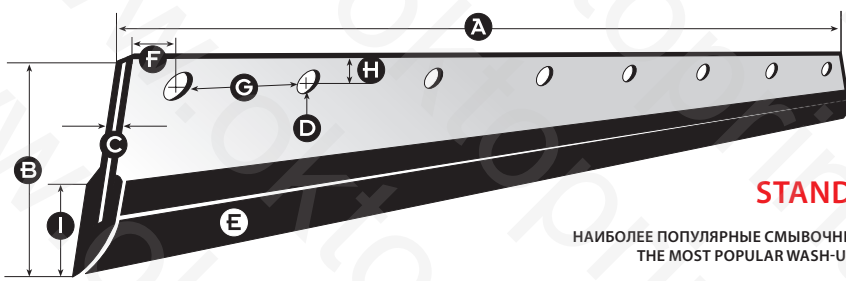

STANDARD

НАИБОЛЕЕ ПОПУЛЯРНЫЕ СМЫВОЧНЫЕ НОЖИ
THE MOST POPULAR WASH-UP BLADES

ВАЖНО: ПРИ ЗАКАЗЕ СМЫВОЧНЫХ НОЖЕЙ СО СПЕЦИАЛЬНОЙ EPDM-РЕЗИНОЙ ДЛЯ УФ-КРАСКИ ЦЕНА ВОЗРАСТАЕТ НА 15%
IMPORTANT: FOR ORDERS OF WASH-UP BLADES WITH THE SPECIAL "EPDM" RUBBER PROFILE FOR "UV" INK: 15% PRICE INCREASE

	ЛЕГЕНДА	KEY
A =	Длина	Length
B =	Ширина	Width
C =	Толщина	Thickness
D =	Количество отверстий	N° of holes
E =	Тип ножа	Blade type
M =	Металл	Metal
R =	Резина	Rubber
MR =	Металл + Резина	Metal + Rubber
F =	Ламинированная Фибра	Laminated Fibre
P =	Пластик	Plastic
T =	Тефлон	Teflon
V =	Вулколлан	Vulcollan

MÜLLER MARTINI - БЕСКОНЕЧНЫЕ ФОРМУЛЯРЫ - CONTINUOUS FORM

КОД КОДЕ	МОДЕЛЬ МАШИНЫ - MACHINE & MODEL	РАЗМЕР SIZE	A		B		C		D	E
			MM	INCHES	MM	INCHES	MM	INCHES		
2450	MÜLLER "PRONTO" 2200 mod. 42		457	17,99"	37	1,46"	0,5	0,02"	5+1	MR
2455	MÜLLER "GRAPHA 50"		530	20,87"	47	1,85"	0,5	0,02"	6	MR
2460	MÜLLER "PROGRESS 20"- "CONCEPT"- PROGRESS1"- СТАНДАРТНЫЙ - STANDARD		530	20,87"	37	1,46"	0,5	0,02"	6+1	MR
2461	MÜLLER "PROGRESS 20"- "CONCEPT"- PROGRESS1"- Vulcollan		530	20,87"	37	1,46"	5	0,20"	6+1	V
2465	MÜLLER "GRAPHA 20" (Пластик/Plastic)		530	20,87"	47	1,85"	3	0,12"	18	P
2470	MÜLLER "GRAPHA 20" (Металл+резина/Metal+rubber)		530	20,87"	47	1,85"	0,5	0,02"	18	MR
2475	MÜLLER "GRAPHA 20" (Пластик/Plastic)		530	20,87"	42	1,65"	3	0,12"	18	P
2480	MÜLLER "GRAPHA 20" (Металл+резина/Metal+rubber)		530	20,87"	42	1,65"	0,5	0,02"	18	MR
2481	MÜLLER MARTINI		730	28,74"	70	2,76"	0,5	0,02"	7	MR
2482	MÜLLER A74		785	30,91"	37	1,46"	0,5	0,02"	10+1	MR
2483	MÜLLER - A 68		695	27,36"	37	1,46"	0,5	0,02"	8+1	MR
2485	MÜLLER "GRAPHA 40"		835	32,87"	37	1,46"	0,5	0,02"	10	MR
2490	MÜLLER "GRAPHA 40" (Пластик/Plastic)		835	32,87"	47	1,85"	5	0,20"	10	P

GOEBEL - БЕСКОНЕЧНЫЕ ФОРМУЛЯРЫ - CONTINUOUS FORM

КОД КОДЕ	МОДЕЛЬ МАШИНЫ - MACHINE & MODEL	РАЗМЕР SIZE	A		B		C		D	E
			MM	INCHES	MM	INCHES	MM	INCHES		
2503	GOEBEL MINIFORMA		465	18,31"	37	1,46"	1	0,04"	5	P
2505	GOEBEL VARIFORMA		562	22,13"	46	1,81"	1	0,04"	7	P
2510	GOEBEL OPTIFORMA		589	23,19"	40	1,57"	1	0,04"	6	P
2515	GOEBEL OPTIFORMA - СТАНДАРТНЫЙ - STANDARD		595	23,43"	35	1,38"	1	0,04"	5+1	P
2517	GOEBEL (PLAN 10)		590	23,23"	55	2,17"	0,5	0,02"	6	MR
2520	GOEBEL ECOPRINT - СТАНДАРТНЫЙ - STANDARD		590	23,23"	57	2,24"	0,5	0,02"	6	MR
2525	GOEBEL MINIFORMA		603	23,74"	50	1,97"	1	0,04"	6	P
2527	GOEBEL NOVAPRINT (PLAN 9)		750	29,53"	55	2,17"	0,5	0,02"	7	MR
2530	GOEBEL OPTIFORMA 840		910	35,83"	55	2,17"	0,5	0,02"	9+2	MR
2532	GOEBEL OPTIFORMA 900		970	38,19"	55	2,17"	0,5	0,02"	10	MR

CODIMAG - БЕСКОНЕЧНЫЕ ФОРМУЛЯРЫ - CONTINUOUS FORM

КОД КОДЕ	МОДЕЛЬ МАШИНЫ - MACHINE & MODEL	РАЗМЕР SIZE	A		B		C		D	E
			MM	INCHES	MM	INCHES	MM	INCHES		
2970	CODIMAG M 14		525	20,67"	37	1,46"	5	0,20"	14	R
2975	CODIMAG M 16		525	20,67"	37	1,46"	5	0,20"	14	R
2977	CODIMAG - VIVA 340 (Резина/Rubber)		361	14,21"	35	1,38"	5	0,20"	9	R
2978	CODIMAG - VIVA 340 - ПЛАСТИК ДЛЯ УФ - PLASTIC FOR "UV"		361	14,21"	35	1,38"	5	0,20"	9	P

MIYAKOSHI - БЕСКОНЕЧНЫЕ ФОРМУЛЯРЫ - CONTINUOUS FORM

КОД КОДЕ	МОДЕЛЬ МАШИНЫ - MACHINE & MODEL	РАЗМЕР SIZE	A		B		C		D	E
			MM	INCHES	MM	INCHES	MM	INCHES		
3069	MIYAKOSHI (ПЛАСТИК/PLASTIC)		496	19,53"	42	1,65"	1	0,04"	7	P
3070	MIYAKOSHI - MSP 18 - DVR/DVF		503	19,80"	34	1,34"	5	0,20"	10	P
3072	MIYAKOSHI - BF		515	20,28"	55	2,17"	5	0,20"	12	P
3071	MIYAKOSHI - MVR 16		518	20,39"	62	2,44"	2	0,08"	10	P
3073	MIYAKOSHI - BF		524	20,63"	40	1,57"	0,5	0,02"	12	MR
3074	MIYAKOSHI		523	20,59"	38	1,50"	5	0,20"	10	P
3075	MIYAKOSHI - MSP 18 - MVF		525	20,67"	55	2,17"	5	0,20"	12	P
3076	MIYAKOSHI DVR 17 (ПЛАСТИК/PLASTIC)		525	20,67"	40	1,57"	3	0,12"	10	P
3080	MIYAKOSHI - MVF 20		584	22,99"	55	2,17"	5	0,20"	10	P
3085	MIYAKOSHI - MVF 22		640	25,20"	55	2,17"	5	0,20"	14	P
3090	MIYAKOSHI		1003	39,49"	50	1,97"	0,5	0,02"	12	MR
3095	MIYAKOSHI - MSP 15		465	18,31"	55	2,17"	5	0,20"	10	P
3097	MIYAKOSHI		654	25,75"	55	2,17"	0,5	0,02"	10	MR
3100	MIYAKOSHI - TECNO "E"									
3102	MIYAKOSHI - TECNO - BOX		514	20,24"	33	1,30"	5	0,20"	11	P
3104	MIYAKOSHI - TECNO - BOX		545	23,50"	55	2,17"	5	0,20"	12	P

DRENT - БЕСКОНЕЧНЫЕ ФОРМУЛЯРЫ - CONTINUOUS FORM

КОД КОДЕ	МОДЕЛЬ МАШИНЫ - MACHINE & MODEL	РАЗМЕР SIZE	A		B		C		D	E
			MM	INCHES	MM	INCHES	MM	INCHES		
2760	DRENT GAZELLE - 9 IMR									
2765	DRENT GAZELLE - 8		482	18,98"	45	1,77"	2	0,08"	5	T
2770	DRENT GAZELLE - 6K - 6L		508	20,00"	34	1,34"	2	0,08"	5	T
2771	DRENT GAZELLE		535	21,06"	30	1,18"	2	0,08"	8	T
2772	DRENT GAZELLE "VISION"		536	21,10"	36	1,42"	4	0,16"	8	T
2775	DRENT GAZELLE - 6P		540	21,26"	40	1,57"	2	0,08"	8	T
2777	DRENT GAZELLE - 6P		540	21,26"	35	1,38"	2	0,08"	8	T
2780	DRENT GAZELLE - 3C		555	21,85"	35	1,38"	5	0,20"	6	R
2785	DRENT GAZELLE - L		564	22,20"	35	1,38"	2	0,08"	6	T
2790	DRENT GAZELLE - 2B		574	22,60"	30	1,18"	5	0,20"	6	R
2792	DRENT GAZELLE "VISION"		573	22,56"	33	1,30"	4	0,16"	6	T
2795	DRENT GAZELLE "VISION"		576	22,68"	40	1,57"	4	0,16"	6	T
2797	DRENT GAZELLE "VISION"		575	22,64"	34	1,34"	4	0,16"	6	T
2800	DRENT GAZELLE - 5E		578	22,76"	50	1,97"	2	0,08"	6	T
2805	DRENT GAZELLE - 4D		583	22,95"	23	0,91"	2	0,08"	8	T
2810	DRENT GAZELLE - 4F - 5G		606	23,86"	45	1,77"	2	0,08"	6	T
2815	DRENT NOVAPRINT		830	32,68"	56	2,20"	0,5	0,02"	8	MR
2820	DRENT "VSOP"		1190	46,85"	55	2,17"	0,5	0,02"	11	MR

ROCKWELL GOSS РУЛОННЫЙ ОФСЕТ GRAPHIC SYSTEM WEB PRESS

КОД КОДЕ	МОДЕЛЬ МАШИНЫ - MACHINE & MODEL	РАЗМЕР SIZE	A		B		C		D	E
			MM	INCHES	MM	INCHES	MM	INCHES		
2690	GOSS - COLORLINE									
2692	GOSS		972	38,27"	58	2,28"	0,5	0,02"	11	MR
2695	GOSS - UNIVERSAL		973	38,31"	64	2,52"	0,5	0,02"	11	MR
2700	GOSS - NEWSLINER									
2705	GOSS - COMMUNITY - SS C 30									
2706	GOSS - G 16		1020	40,16"	64	2,52"	0,5	0,02"	11	MR
2708	GOSS		1058	41,65"	58	2,28"	0,5	0,02"	11	MR
3496	GOSS (PLAN 4)		898	35,35"	63	2,48"	0,5	0,02"	11	MR
3497	GOSS (PLAN 58)		900	35,43"	64	2,52"	0,5	0,02"	9	MR
3500	GOSS (PLAN 2)		972	38,27"	63	2,48"	0,5	0,02"	11	MR
3502	GOSS (PLAN 60)		972	38,27"	58	2,28"	0,5	0,02"	11	MR
3510	GOSS		990	38,98"	90	3,54"	1	0,04"	7	P
3512	GOSS (PLAN 1)		1058	41,65"	63	2,48"	0,5	0,02"	11	MR
3513	GOSS (PLAN 43)		1058	41,65"	58	2,28"	0,5	0,02"	11	MR
3514	GOSS (PLAN 54)		1548	60,94"	63	2,48"	0,5	0,02"	0	MR
3516	GOSS (PLAN 18)		1548	60,94"	63	2,48"	0,5	0,02"	12	MR
3519	GOSS (PLAN 20)		1738	68,43"	63	2,48"	0,5	0,02"	14	MR
3523	GOSS (PLAN 12)		1768	69,60"	63	2,48"	0,5	0,02"	14	MR

TIMSONS - РОТАЦИЯ - ROTARY MACHINE

КОД КОДЕ	МОДЕЛЬ МАШИНЫ - MACHINE & MODEL	РАЗМЕР SIZE	A		B		C		D	E
			MM	INCHES	MM	INCHES	MM	INCHES		
3010	TIMSONS - TWUN - UP MARK II		521	20,51"	37	1,46"	0,5	0,02"	8	MR
3015	TIMSONS - T17		534	21,02"	53	2,09"	0,5	0,02"	0	MR
3016	TIMSONS		584	23,00"	53	2,09"	0,5	0,02"	0	MR
3020	TIMSONS - T32 (40")		1080	42,52"	53	2,09"	0,5	0,02"	0	MR
3025	TIMSONS - T32 (47")		1270	50,00"	53	2,09"	0,5	0,02"	0	MR
3030	TIMSONS - T32 (53")		1410	55,51"	53	2,09"	0,5	0,02"	0	MR
3031	TIMSONS		1525	60,04"	53	2,09"	0,5	0,02"	0	MR

WIFAG - РОТАЦИЯ - ROTARY MACHINE

КОД КОДЕ	МОДЕЛЬ МАШИНЫ - MACHINE & MODEL	РАЗМЕР SIZE	A		B		C		D	E
			MM	INCHES	MM	INCHES	MM	INCHES		
3035	WIFAG - OF 7 (PLAN 50)		740	29,13"	31	1,22"	0,5	0,02"	0	MR
3036	WIFAG - (PLAN 17)		870	34,25"	45	1,77"	0,5	0,02"	0	MR
3040	WIFAG - OF 92		880	34,65"	37	1,46"	0,5	0,02"	0	MR
3041	WIFAG - (PLAN 64)		1290	50,79"	45	1,77"	0,5	0,02"	0	MR
3042	WIFAG		1450	57,09"	45	1,77"	0,5	0,02"	0+4	MR
3043	WIFAG - (PLAN 23)		1480	58,27"	45	1,77"	0,5	0,02"	0	MR
3044	WIFAG		1320	51,97"	65	2,56"	0,5	0,02"	6	MR
3039	WIFAG - (PLAN 83)		1370	53,94"	45	1,77"	0,5	0,02"	0	MR
3045	WIFAG		1430	56,30"	50	1,97"	1	0,04"	9	P
3037	WIFAG - (PLAN 73)		1560	61,42"	45	1,77"	0,5	0,02"	0	MR
3046	WIFAG		1610	63,39"	45	1,77"	0,5	0,02"	0	MR
3047	WIFAG - (PLAN 51)		1960	77,17"	45	1,77"	0,5	0,02"	0	MR
3048	WIFAG - (PLAN 5)		1800	70,87"	45	1,77"	0,5	0,02"	0	MR
3049	WIFAG - (PLAN 48)		1800	70,87"	31	1,22"	0,5	0,02"	0	MR
3038	WIFAG - (PLAN 74)		1800	70,87"	38	1,50"	0,5	0,02"	0	MR

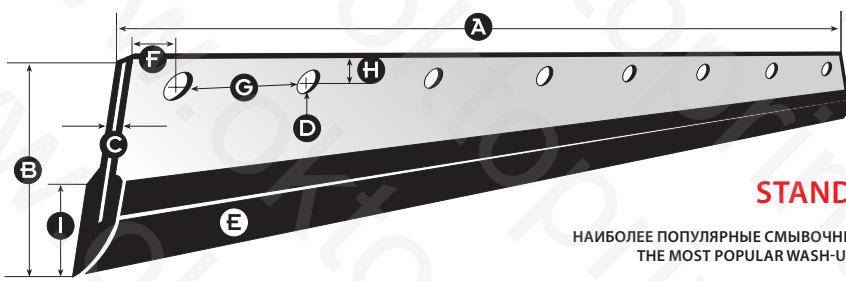

STANDARD

НАИБОЛЕЕ ПОПУЛЯРНЫЕ СМЫВОЧНЫЕ НОЖИ
THE MOST POPULAR WASH-UP BLADES

ВАЖНО: ПРИ ЗАКАЗЕ СМЫВОЧНЫХ НОЖЕЙ СО СПЕЦИАЛЬНОЙ EPDM-РЕЗИНОЙ ДЛЯ УФ-КРАСКИ ЦЕНА ВОЗРАСТАЕТ НА 15%
IMPORTANT: FOR ORDERS OF WASH-UP BLADES WITH THE SPECIAL "EPDM" RUBBER PROFILE FOR "UV" INK: 15% PRICE INCREASE

	ЛЕГЕНДА	KEY
A =	Длина	Length
B =	Ширина	Width
C =	Толщина	Thickness
D =	Количество отверстий	N° of holes
E =	Тип ножа	Blade type
M =	Металл	Metal
R =	Резина	Rubber
MR =	Металл + Резина	Metal + Rubber
F =	Ламинированная Фибра	Laminated Fibre
P =	Пластик	Plastic
T =	Тефлон	Teflon
V =	Вулколлан	Vulcollan

WEILAND

КОД КОДЕ	МОДЕЛЬ МАШИНЫ - MACHINE & MODEL	РАЗМЕР SIZE	A		B		C		D	E
			MM	INCHES	MM	INCHES	MM	INCHES		
3195	WEILAND		1060	41,73"	50	1,97"	2	0,08"	21	MR
3200	WEILAND - ROTO OFFSET		1180	46,46"	50	1,97"	2	0,08"	23	MR
3205	WEILAND - MFR 650		690	27,17"	50	1,97"	2	0,08"	14	MR

GALLUS - УЗКОРУЛОННАЯ ПЕЧАТЬ - LABEL PRINTING PRESSES

КОД КОДЕ	МОДЕЛЬ МАШИНЫ - MACHINE & MODEL	РАЗМЕР SIZE	A		B		C		D	E
			MM	INCHES	MM	INCHES	MM	INCHES		
2715	GALLUS Q33		185	7,29"	27	1,07"	1	0,04"	4	P
2716	GALLUS		190	7,48"	27	1,07"	0,3	0,12"	4	V
2720	GALLUS - R 160 (PLAN 15)		222	8,74"	35	1,38"	0,5	0,02"	5	MR
2725	GALLUS - R 200 - СТАНДАРТНЫЙ - STANDARD		252	9,92"	35	1,38"	0,5	0,02"	6	MR
2726	GALLUS - R 200 Новая модель/New model		244	9,60"	35	1,38"	0,5	0,02"	6	MR
2727	GALLUS - TCS 250		292	11,50"	35	1,38"	0,5	0,02"	0	MR
2730	GALLUS - R 250 - (PLAN 16) - СТАНДАРТНЫЙ - STANDARD		322	12,64"	56	2,20"	0,5	0,02"	7	MR
2735	GALLUS - R 300		362	14,25"	58	2,28"	0,5	0,02"	7	MR
2740	GALLUS - 2000		375	14,76"	35	1,46"	0,5	0,02"	6	MR

NILPETER - УЗКОРУЛОННАЯ ПЕЧАТЬ - LABEL PRINTING PRESSES

КОД КОДЕ	МОДЕЛЬ МАШИНЫ - MACHINE & MODEL	РАЗМЕР SIZE	A		B		C		D	E
			MM	INCHES	MM	INCHES	MM	INCHES		
3050	NILPETER B 200		240	9,45"	25	0,98"	5	0,20"	0	V
3055	NILPETER B 280		335	13,19"	25	0,98"	5	0,20"	0	V
3057	NILPETER B 3300		392	15,43"	35	1,38"	1	0,04"	5	P

IWASAKI TEKKO - УЗКОРУЛОННАЯ ПЕЧАТЬ - LABEL PRINTING PRESSES

КОД КОДЕ	МОДЕЛЬ МАШИНЫ - MACHINE & MODEL	РАЗМЕР SIZE	A		B		C		D	E
			MM	INCHES	MM	INCHES	MM	INCHES		
2830	IWASAKI 50		542	21,34"	50	1,97"	2	0,08"	7	MR
2835	IWASAKI TR25		315	12,40"	50	1,97"	2	0,08"	5	P
2837	IWASAKI TR25		330	12,99"	50	1,97"	2	0,08"	5	MR
2840	IWASAKI TR2		393	15,47"	48	1,89"	5	0,20"	6	V

FLEXI-BOBINE - УЗКОРУЛОННАЯ ПЕЧАТЬ - LABEL PRINTING PRESSES - БЕСКОНЕЧНЫЕ ФОРМУЛЯРЫ - CONTINUOUS FORM

КОД КОДЕ	МОДЕЛЬ МАШИНЫ - MACHINE & MODEL	РАЗМЕР SIZE	A		B		C		D	E
			MM	INCHES	MM	INCHES	MM	INCHES		
2850	FLEXI BOBINE 12		500	19,69"	20	0,79"	6	0,24"	9	MR
2855	FLEXI BOBINE		499	19,65"	58	2,28"	0,5	0,02"	15	MR
2860	FLEXI BOBINE (Тефлон/Teflon)		513	20,20"	44	1,73"	3	0,12"	15	T
2865	FLEXI BOBINE 10 (Тефлон/Teflon)		530	20,87"	44	1,73"	3	0,12"	15	T
2870	FLEXI BOBINE (Нейлон/NYLON)		534	21,02"	42	1,65"	3	0,12"	18	P
2875	SEAILLES ET TISON ST 150		460	18,11"	20	0,79"	6	0,24"	8	MR
2880	TISON PLATINA/PLATEN (Резина/Rubber)		472	18,58"	35	1,38"	3	0,12"	5	R
2882	TISON PLATINA/PLATEN (Резина/Rubber)		487	19,17"	45	1,77"	5	0,20"	13	R
2885	SEAILLES ET TISON SPRINT 1300									
2890	SEAILLES ET TISON SPRINT 1600		465	18,31"	20	0,79"	6	0,24"	7	MR
2895	SEAILLES ET TISON SPRINT 2000		522	20,55"	40	1,57"	0,5	0,02"	8	MR

SANCKI - ПЕЧАТЬ ЭТИКЕТКИ - FOR LABELS

КОД КОДЕ	МОДЕЛЬ МАШИНЫ - MACHINE & MODEL	РАЗМЕР SIZE	A		B		C		D	E
			MM	INCHES	MM	INCHES	MM	INCHES		
3300	SANCKI 200		222	8,74"	37	1,46"	0,5	0,02"	5	MR

УКІТА - ПЕЧАТЬ ЭТИКЕТКИ - FOR LABELS

КОД КОДЕ	МОДЕЛЬ МАШИНЫ - MACHINE & MODEL	РАЗМЕР SIZE	A		B		C		D	E
			MM	INCHES	MM	INCHES	MM	INCHES		
3320	УКІТА		420	16,54"	43	1,69"	0,5	0,02"	9	MR

DIDDE - БЕСКОНЕЧНЫЕ ФОРМУЛЯРЫ - CONTINUOUS FORM

КОД КОДЕ	МОДЕЛЬ МАШИНЫ - MACHINE & MODEL	РАЗМЕР SIZE	A		B		C		D	E
			MM	INCHES	MM	INCHES	MM	INCHES		
2540	DIDDE GLASER "APOLLO"		405	15,94"	37	1,46"	2	0,08"	7	P
2545	DIDDE CONSERVER		393	15,47"	58	2,28"	0,5	0,02"	5	MR
2550	DIDDE GLASER 860		495	19,49"	35	1,38"	2	0,08"	7	P
2555	DIDDE GLASER MVP		495	19,49"	58	2,28"	0,5	0,02"	5	MR
2560	DIDDE GLASER VIP		570	22,44"	35	1,38"	2	0,08"	8	P

SCHRIBER - БЕСКОНЕЧНЫЕ ФОРМУЛЯРЫ - CONTINUOUS FORM

КОД КОДЕ	МОДЕЛЬ МАШИНЫ - MACHINE & MODEL	РАЗМЕР SIZE	A		B		C		D	E
			MM	INCHES	MM	INCHES	MM	INCHES		
2580	SCHRIBER 500		515	20,28"	50	1,97"	0,5	0,02"	6	MR
2585	SCHRIBER 800		550	21,65"	50	1,97"	0,5	0,02"	6	MR
2590	SCHRIBER 835		604	23,78"	50	1,97"	0,5	0,02"	7	MR
2595	SCHRIBER 1000		735	28,94"	65	2,56"	0,5	0,02"	8	MR

STEVENS - БЕСКОНЕЧНЫЕ ФОРМУЛЯРЫ - CONTINUOUS FORM

КОД КОДЕ	МОДЕЛЬ МАШИНЫ - MACHINE & MODEL	РАЗМЕР SIZE	A		B		C		D	E
			MM	INCHES	MM	INCHES	MM	INCHES		
2670	STEVENS		527	20,75"	52	2,05"	0,5	0,02"	6	MR
2675	STEVENS 1000		680	26,77"	50	1,97"	0,5	0,02"	7	MR
2680	STEVENS		578	22,76"	50	1,97"	0,5	0,02"	6	MR
2682	STEVENS		914	35,98"	60	2,36"	2	0,08"	17	P

GIBLER - БЕСКОНЕЧНЫЕ ФОРМУЛЯРЫ - CONTINUOUS FORM

КОД КОДЕ	МОДЕЛЬ МАШИНЫ - MACHINE & MODEL	РАЗМЕР SIZE	A		B		C		D	E
			MM	INCHES	MM	INCHES	MM	INCHES		
2990	GIBLER		618	24,33"	25	0,98"	5	0,20"	0	R
2995	GIBLER		550	21,65"	25	0,98"	5	0,20"	0	R
3000	GIBLER 520		914	35,98"	38	1,50"	0,5	0,02"	13	MR

DOVERSTAR

КОД КОДЕ	МОДЕЛЬ МАШИНЫ - MACHINE & MODEL	РАЗМЕР SIZE	A		B		C		D	E
			MM	INCHES	MM	INCHES	MM	INCHES		
3160	DOVERSTAR 512		588	23,15"	35	1,38"	3	0,12"	7	V

COLORJET

КОД КОДЕ	МОДЕЛЬ МАШИНЫ - MACHINE & MODEL	РАЗМЕР SIZE	A		B		C		D	E
			MM	INCHES	MM	INCHES	MM	INCHES		
3180	COLORJET		380	14,96"	64	2,52"	0,5	0,02"	4	MR

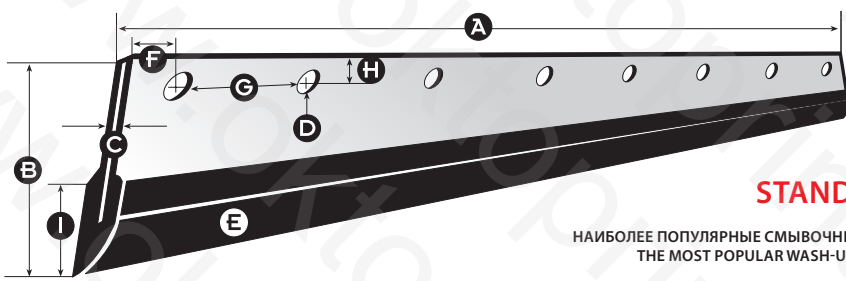

STANDARD

НАИБОЛЕЕ ПОПУЛЯРНЫЕ СМЫВОЧНЫЕ НОЖИ
THE MOST POPULAR WASH-UP BLADES

	ЛЕГЕНДА	KEY
A =	Длина	Length
B =	Ширина	Width
C =	Толщина	Thickness
D =	Количество отверстий	N° of holes
E =	Тип ножа	Blade type
M =	Металл	Metal
R =	Резина	Rubber
MR =	Металл + Резина	Metal + Rubber
F =	Ламинированная Фибра	Laminated Fibre
P =	Пластик	Plastic
T =	Тефлон	Teflon
V =	Вулколан	Vulcollan

ВАЖНО: ПРИ ЗАКАЗЕ СМЫВОЧНЫХ НОЖЕЙ СО СПЕЦИАЛЬНОЙ EPDM-РЕЗИНОЙ ДЛЯ УФ-КРАСКИ ЦЕНА ВОЗРАСТАЕТ НА 15%
IMPORTANT: FOR ORDERS OF WASH-UP BLADES WITH THE SPECIAL "EPDM" RUBBER PROFILE FOR "UV" INK: 15% PRICE INCREASE

NEW MEC - БЕСКОНЕЧНЫЕ ФОРМУЛЯРЫ - CONTINUOUS FORM

КОД КОДЕ	МОДЕЛЬ МАШИНЫ - MACHINE & MODEL	РАЗМЕР SIZE	A		B		C		D	E
			MM	INCHES	MM	INCHES	MM	INCHES		
2910	NEW MEC - RD 580		700	27,56"	58	2,28"	0,5	0,02"	8	MR
2915	NEW MEC - RD 700		700	27,56"	58	2,28"	0,5	0,02"	8	MR

FORM CONSULTA - БЕСКОНЕЧНЫЕ ФОРМУЛЯРЫ - CONTINUOUS FORM

КОД КОДЕ	МОДЕЛЬ МАШИНЫ - MACHINE & MODEL	РАЗМЕР SIZE	A		B		C		D	E
			MM	INCHES	MM	INCHES	MM	INCHES		
2930	FORM CONSULTA FC 50		550	21,65"	25	0,98"	0,5	0,02"	8	MR
2935	FORM CONSULTA FC 50 (Старая модель/Old model)		570	22,44"	23	0,91"	6	0,24"	12	T
2945	FORM CONSULTA VS 650		550	21,65"	25	0,98"	0,5	0,02"	8	MR
2950	FORM CONSULTA VS 760									

CERUTTI

КОД КОДЕ	МОДЕЛЬ МАШИНЫ - MACHINE & MODEL	РАЗМЕР SIZE	A		B		C		D	E
			MM	INCHES	MM	INCHES	MM	INCHES		
3240	CERUTTI		1060	41,73"	64	2,52"	0,5	0,02"	11	MR

MAGNUM

КОД КОДЕ	МОДЕЛЬ МАШИНЫ - MACHINE & MODEL	РАЗМЕР SIZE	A		B		C		D	E
			MM	INCHES	MM	INCHES	MM	INCHES		
3260	MAGNUM		561	22,09"	45	1,77"	5	0,20"	12	R

WINCLER

КОД КОДЕ	МОДЕЛЬ МАШИНЫ - MACHINE & MODEL	РАЗМЕР SIZE	A		B		C		D	E
			MM	INCHES	MM	INCHES	MM	INCHES		
3280	WINCLER 212		475	18,70"	47	1,85"	0,5	0,02"	5	MR

IMER

КОД КОДЕ	МОДЕЛЬ МАШИНЫ - MACHINE & MODEL	РАЗМЕР SIZE	A		B		C		D	E
			MM	INCHES	MM	INCHES	MM	INCHES		
3340	IMER		552	21,73"	64	2,52"	0,5	0,02"	5	MR
3345	IMER R 1200		500	19,69"	64	2,52"	0,5	0,02"	5	MR
3347	IMER (Vulcollan)		542	21,34"	40	1,58"	4	0,16"	0	V

CONSERVER PRESS

КОД КОДЕ	МОДЕЛЬ МАШИНЫ - MACHINE & MODEL	РАЗМЕР SIZE	A		B		C		D	E
			MM	INCHES	MM	INCHES	MM	INCHES		
3465	CONSERVER PRESS		395	15,55"	57	2,24"	0,5	0,02"	5	MR

MODELLI VARI

КОД КОДЕ	МОДЕЛЬ МАШИНЫ - MACHINE & MODEL	РАЗМЕР SIZE	A		B		C		D	E
			MM	INCHES	MM	INCHES	MM	INCHES		
3480	ROSSITECH (PROTOTYPE)		2100	82,68"	74	2,91"	0,5	0,02"	22	MR
3495	TEXCELL		250	9,84"	38	1,50"	5	0,20"	7	R
3520	OMET MULTIFLEX "UV"		353	13,90"	25	0,98"	5	0,20"	6	V

TOSHIBA

КОД КОДЕ	МОДЕЛЬ МАШИНЫ - MACHINE & MODEL	РАЗМЕР SIZE	A		B		C		D	E
			MM	INCHES	MM	INCHES	MM	INCHES		
3540	TOSHIBA PRINTING OA 800		981	38,62"	61	2,40"	0,5	0,02"	11	MR
3545	TOSHIBA 6		1331	52,40"	62	2,44"	0,5	0,02"	14	MR

LABELMAN

КОД КОДЕ	МОДЕЛЬ МАШИНЫ - MACHINE & MODEL	РАЗМЕР SIZE	A		B		C		D	E
			MM	INCHES	MM	INCHES	MM	INCHES		

AKIRA

КОД КОДЕ	МОДЕЛЬ МАШИНЫ - MACHINE & MODEL	РАЗМЕР SIZE	A		B		C		D	E
			MM	INCHES	MM	INCHES	MM	INCHES		
3118	AKIRA 18 EF		526	20,71"	52	2,05"	0,5	0,02"	8	MR
3120	AKIRA 18 EF		526	20,71"	58	2,28"	0,5	0,02"	8	MR

C.M.C. CARDANI

КОД КОДЕ	МОДЕЛЬ МАШИНЫ - MACHINE & MODEL	РАЗМЕР SIZE	A		B		C		D	E
			MM	INCHES	MM	INCHES	MM	INCHES		
3140	C.M.C. CARDANI		570	22,44"	43	1,70"	0,5	0,02"	7	MR

FAG TORCHIO TIRAPROVE - FAG PROOFING PRESSES

КОД КОДЕ	МОДЕЛЬ МАШИНЫ - MACHINE & MODEL	РАЗМЕР SIZE	A		B		C		D	E
			MM	INCHES	MM	INCHES	MM	INCHES		
1820	FAG - OP 104/ALFA/BETA	72 x 102	1090	42,91"	58	2,28"	0,5	0,02"	18	MR
1830	FAG - ZETACONT	72 x 102	1080	42,52"	48	1,89"	0,5	0,02"	15	MR
1835	ADAST ZETACONT 701	72 x 102	1083	42,64"	45	1,77"	3	0,12"	15	P
1840	FAG SPEED STELLARE		1158	45,59"	47	1,85"	0,5	0,02"	13	MR

KOREX TORCHIO TIRAPROVE - KOREX PROOFING PRESSES

КОД КОДЕ	МОДЕЛЬ МАШИНЫ - MACHINE & MODEL	РАЗМЕР SIZE	A		B		C		D	E
			MM	INCHES	MM	INCHES	MM	INCHES		
1850	KOREX 02	50 x 70	720	28,35"	42	1,65"	5	0,20"	11	P
1855	KOREX (Старые модели без отверстий/Old model without holes)	72 x 102	1035	40,75"	31	1,22"	5	0,20"	0	P
1860	KOREX (Старые модели с отверстиями/Old model with holes)	72 x 102	1035	40,75"	42	1,65"	5	0,20"	15	P
1865	KOREX (Новая модель/New model)	72 x 102	1090	42,91"	31	1,22"	5	0,20"	0	P

KO - PAK

КОД КОДЕ	МОДЕЛЬ МАШИНЫ - MACHINE & MODEL	РАЗМЕР SIZE	A		B		C		D	E
			MM	INCHES	MM	INCHES	MM	INCHES		
3374	KO - PAK 180		189	7,44"	54	2,13"	1	0,04"	7	P
3375	KO - PAK 250/250 SUPER "UV"		280	11,02"	43	1,69"	0,5	0,02"	6	MR
3380	KO - PAK 400		410	16,14"	43	1,69"	0,5	0,02"	9	MR

MABER

КОД КОДЕ	МОДЕЛЬ МАШИНЫ - MACHINE & MODEL	РАЗМЕР SIZE	A		B		C		D	E
			MM	INCHES	MM	INCHES	MM	INCHES		
3400	MABER		1006	39,61"	55	2,17"	3	0,12"	0	P

ORIS

КОД КОДЕ	МОДЕЛЬ МАШИНЫ - MACHINE & MODEL	РАЗМЕР SIZE	A		B		C		D	E
			MM	INCHES	MM	INCHES	MM	INCHES		
3420	ORIS		885	34,84"	38	1,50"	0,5	0,02"	0	MR
3422	ORIS (Vulcollan)		882	34,72"	33	1,30"	5	0,20"	0	V
3424	ORIS 9000 (Vulcollan)		1100	43,31"	50	1,97"	3	0,12"	0	V

SANJO

КОД КОДЕ	МОДЕЛЬ МАШИНЫ - MACHINE & MODEL	РАЗМЕР SIZE	A		B		C		D	E
			MM	INCHES	MM	INCHES	MM	INCHES		
3430	SANJO - P03 - 250		360	14,17"	26	1,02"	1	0,04"	5	P
3432	SANJO - P03 - 250		360	14,17"	35	1,38"	1	0,04"	5	P
3434	SANJO - P03 - 350		440	17,32"	26	1,02"	1	0,04"	6	P
3435	SANJO - P03 - 350		442	17,40"	31	1,22"	1	0,04"	6	P
3436	SANJO - P03 - 350		442	17,40"	35	1,38"	1	0,04"	6	P
3437	SANJO		440	17,32"	36	1,42"	1	0,04"	6	P

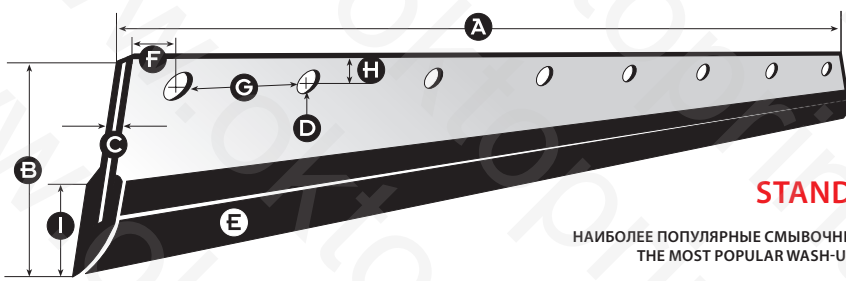

STANDARD

НАИБОЛЕЕ ПОПУЛЯРНЫЕ СМЫВОЧНЫЕ НОЖИ
THE MOST POPULAR WASH-UP BLADES

	ЛЕГЕНДА	KEY
A =	Длина	Length
B =	Ширина	Width
C =	Толщина	Thickness
D =	Количество отверстий	N° of holes
E =	Тип ножа	Blade type
M =	Металл	Metal
R =	Резина	Rubber
MR =	Металл + Резина	Metal + Rubber
F =	Ламинированная Фибра	Laminated Fibre
P =	Пластик	Plastic
T =	Тефлон	Teflon
V =	Вулколан	Vulcollan

ВАЖНО: ПРИ ЗАКАЗЕ СМЫВОЧНЫХ НОЖЕЙ СО СПЕЦИАЛЬНОЙ EPDM-РЕЗИНОЙ ДЛЯ УФ-КРАСКИ ЦЕНА ВОЗРАСТАЕТ НА 15%
IMPORTANT: FOR ORDERS OF WASH-UP BLADES WITH THE SPECIAL "EPDM" RUBBER PROFILE FOR "UV" INK: 15% PRICE INCREASE

HAMILTONS

КОД КОДЕ	МОДЕЛЬ МАШИНЫ - MACHINE & MODEL	РАЗМЕР SIZE	A		B		C		D	E
			MM	INCHES	MM	INCHES	MM	INCHES		
3440	HAMILTONS		860	33,86"	60	2,36"	2	0,08"	16	P
3442	HAMILTONS		557	21,93"	63	2,48"	2	0,08"	20	P
3443	HAMILTONS		550	21,65"	63	2,48"	1	0,04"	20	P

MORGAN

КОД КОДЕ	МОДЕЛЬ МАШИНЫ - MACHINE & MODEL	РАЗМЕР SIZE	A		B		C		D	E
			MM	INCHES	MM	INCHES	MM	INCHES		
3450	MORGAN 904		427	16,81"	55	2,17"	0,5	0,02"	5	MR
3452	MORGAN 58		520	20,47"	55	2,17"	0,5	0,02"	6	MR
3453	MORGAN 904 (Пластик/Plastic)		425	16,73"	55	2,17"	3	0,12"	5	P
3454	MORGAN 904		425	16,73"	55	2,17"	0,5	0,02"	5	MR
3449	MORGAN - 85 - 27 - QRI		490	19,29"	90	3,54"	2	0,08"	12	MR
3451	MORGAN 905		526	20,71"	55	2,17"	0,5	0,02"	6	MR

ATM

КОД КОДЕ	МОДЕЛЬ МАШИНЫ - MACHINE & MODEL	РАЗМЕР SIZE	A		B		C		D	E
			MM	INCHES	MM	INCHES	MM	INCHES		
3220	ATM		872	34,33"	64	2,52"	0,5	0,02"	18	MR

CHAMBON

КОД КОДЕ	МОДЕЛЬ МАШИНЫ - MACHINE & MODEL	РАЗМЕР SIZE	A		B		C		D	E
			MM	INCHES	MM	INCHES	MM	INCHES		
3455	CHAMBON		657	25,87"	46	1,81"	1	0,04"	7	P
3456	CHAMBON		734	28,90"	30	1,19"	1	0,04"	0	P
3457	CHAMBON		792	31,18"	40	1,58"	1	0,04"	0	P

ТОКО

КОД КОДЕ	МОДЕЛЬ МАШИНЫ - MACHINE & MODEL	РАЗМЕР SIZE	A		B		C		D	E
			MM	INCHES	MM	INCHES	MM	INCHES		
3460	ТОКО 2000		344	13,54"	25	0,98"	3	0,12"	5	P

ТАЙЮ

КОД КОДЕ	МОДЕЛЬ МАШИНЫ - MACHINE & MODEL	РАЗМЕР SIZE	A		B		C		D	E
			MM	INCHES	MM	INCHES	MM	INCHES		
3461	ТАЙЮ 512 A		512	20,16"	29	1,14"	5	0,20"	11	R
3462	ТАЙЮ TLC - 250 (EPDM)		281	1,11"	42	1,65"	0,5	0,02"	6	MR
3463	ТАЙЮ PRESS Для УФ красок/For "UV"		504	19,84"	33	1,30"	0,5	0,02"	11	MR
3464	ТАЙЮ PRESS Для УФ красок/For "UV"		626	24,64"	42	1,65"	0,5	0,02"	8	MR
3466	ТАЙЮ PRESS 410 Для УФ красок/For "UV"		565	22,24"	28	1,10"	5	0,20"	11	V

ZIRKON

КОД КОДЕ	МОДЕЛЬ МАШИНЫ - MACHINE & MODEL	РАЗМЕР SIZE	A		B		C		D	E
			MM	INCHES	MM	INCHES	MM	INCHES		
3570	ZIRKON SUPRA 660		730	28,74"	45	1,77"	0,5	0,02"	10	MR
3571	ZIRKON 62 - 10		760	29,92"	25	0,98"	2	0,08"	0	P

BAKER PERKINS

КОД КОДЕ	МОДЕЛЬ МАШИНЫ - MACHINE & MODEL	РАЗМЕР SIZE	A		B		C		D	E
			MM	INCHES	MM	INCHES	MM	INCHES		
3575	BAKER PERKINS		1030	40,55"	64	2,52"	0,5	0,02"	11	MR

POLLY

КОД КОДЕ	МОДЕЛЬ МАШИНЫ - MACHINE & MODEL	РАЗМЕР SIZE	A		B		C		D	E
			MM	INCHES	MM	INCHES	MM	INCHES		
3580	POLLY 66		665	26,18"	30	1,18"	3	0,12"	0	P

COLOR METAL

КОД КОДЕ	МОДЕЛЬ МАШИНЫ - MACHINE & MODEL	РАЗМЕР SIZE	A		B		C		D	E
			MM	INCHES	MM	INCHES	MM	INCHES		
3585	CHAMPION COLORMETAL		1180	46,46"	78	3,07"	0,5	0,02"	15	MR
420	PERLE/COLORMETAL		810	31,89"	65	2,26"	0,5	0,02"	0	MR

ЕРІКОС

КОД КОДЕ	МОДЕЛЬ МАШИНЫ - MACHINE & MODEL	РАЗМЕР SIZE	A		B		C		D	E
			MM	INCHES	MM	INCHES	MM	INCHES		
3587	ЕРІКОС		592	23,31"	47	1,85"	0,5	0,02"	8	MR

AUTOMATION

КОД КОДЕ	МОДЕЛЬ МАШИНЫ - MACHINE & MODEL	РАЗМЕР SIZE	A		B		C		D	E
			MM	INCHES	MM	INCHES	MM	INCHES		
3590	AUTOMATION MULTI 460		460	18,11"	64	2,52"	0,5	0,02"	5	MR
3592	AUTOMATION A 4 - 485		485	19,09"	64	2,52"	0,5	0,02"	5	MR

GUANG (China)

КОД КОДЕ	МОДЕЛЬ МАШИНЫ - MACHINE & MODEL	РАЗМЕР SIZE	A		B		C		D	E
			MM	INCHES	MM	INCHES	MM	INCHES		
3600	GUANG PZ 465		712	28,03"	51	2,00"	0,5	0,02"	8	MR

BIELOMATIC

КОД КОДЕ	МОДЕЛЬ МАШИНЫ - MACHINE & MODEL	РАЗМЕР SIZE	A		B		C		D	E
			MM	INCHES	MM	INCHES	MM	INCHES		
3610	BIELOMATIC		620	24,41"	27	1,06"	4	0,16"	13	V

TKS TOKIO KIKAI SEISAKUSHO

КОД КОДЕ	МОДЕЛЬ МАШИНЫ - MACHINE & MODEL	РАЗМЕР SIZE	A		B		C		D	E
			MM	INCHES	MM	INCHES	MM	INCHES		
3615	TKS - B2		935	36,81"	55	2,17"	0,5	0,02"	10	MR

ARSOMA

КОД КОДЕ	МОДЕЛЬ МАШИНЫ - MACHINE & MODEL	РАЗМЕР SIZE	A		B		C		D	E
			MM	INCHES	MM	INCHES	MM	INCHES		
3620	ARSOMA - Vulcollan		620	24,41"	22	0,87"	5	0,20"	0	V

HEAT

КОД КОДЕ	МОДЕЛЬ МАШИНЫ - MACHINE & MODEL	РАЗМЕР SIZE	A		B		C		D	E
			MM	INCHES	MM	INCHES	MM	INCHES		
3625	HEAT		403	15,87"	49	1,93"	0,5	0,02"	5	MR

INDIGO

КОД КОДЕ	МОДЕЛЬ МАШИНЫ - MACHINE & MODEL	РАЗМЕР SIZE	A		B		C		D	E
			MM	INCHES	MM	INCHES	MM	INCHES		
3630	INDIGO HP 550		345	13,58"	30	1,18"	2	0,08"	0	P

ALPHA GIKEN

КОД КОДЕ	МОДЕЛЬ МАШИНЫ - MACHINE & MODEL	РАЗМЕР SIZE	A		B		C		D	E
			MM	INCHES	MM	INCHES	MM	INCHES		
3635	ALPHA GIKEN		322	12,68"	43	1,69"	0,5	0,02"	4	MR

СМЫВОЧНЫЕ НОЖИ ПО ИНДИВИДУАЛЬНОМУ ЗАПРОСУ

Ножи не вошедшие в каталог могут быть изготовлены по индивидуальному проекту; минимальная партия оговаривается особо.

Пожалуйста, заполните форму.
Все параметры обязательны.

MANUFACTURE OF SPECIAL OR PERSONALISED WASH-UP BLADES

Any blade non included in this catalogue can be made on specific request; the minimum order requirement is to be agreed.

Please complete the form below with all the details

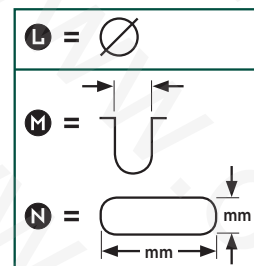
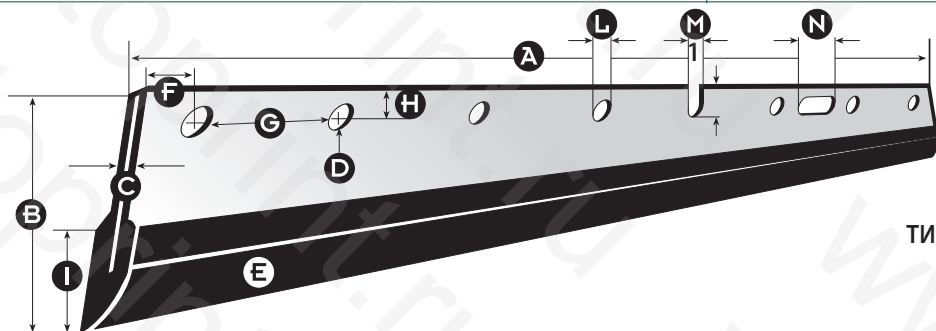

ТИПЫ ОТВЕРСТИЙ
HOLE TYPES

НАИМЕНОВАНИЕ МАШИНЫ И МОДЕЛЬ

MACHINE NAME
AND MODEL

N.B.: Пожалуйста указывайте размеры в мм максимально точно, чтобы быть уверенными в конечном результате

N.B.: Please indicate the exact measurements in mm./inches to ensure the perfect reproduction of the blade

ПАРАМЕТРЫ		мм	KEY		mm	inch.
A = Длина ножа			A = Length of blade			
B = Ширина			B = Overall width			
C = Толщина			C = Thickness			
D = Количество отверстий			D = No. of holes			
E = Тип ножа			E = Blade type			
MR = Металл+резина	<input type="checkbox"/>		MR = Metal + rubber	<input type="checkbox"/>		
R = Резина	<input type="checkbox"/>		R = Rubber	<input type="checkbox"/>		
P = Пластик	<input type="checkbox"/>		P = Special plastic	<input type="checkbox"/>		
T = Тефлон	<input type="checkbox"/>		T = Teflon	<input type="checkbox"/>		
V = Vulcollan	<input type="checkbox"/>		V = Vulcollan	<input type="checkbox"/>		
F = Ламинированная фибра	<input type="checkbox"/>		F = Laminated fibre	<input type="checkbox"/>		
F = Расстояние от чистой кромки до центра первого отверстия			F = Distance from blade end to centre of first hole			
G = Шаг отверстий (от центра до центра)			G = Hole spacing (centre to centre)			
H = Расстояние от края ножа до центра первого отверстия			H = Distance from blade edge to centre of hole			
I = Ширина резины			I = Rubber profile width			
L = Диаметр отверстия			L = Diametre of hole			
M = Размер паза			M = Sizes of slot			
N = Размеры овального отверстия			N = Sizes of oval hole			
"STANDARD" = Резина "NBR" твердостью 95 shore (жесткая) "STANDARD"	<input type="checkbox"/>		"STANDARD" = Rubber profile "NBR" with 95 "STANDARD" shore (hard)	<input type="checkbox"/>		
"SOFT" = Резина "NBR" твердостью 85 shore (мягкая) "SPECIAL"	<input type="checkbox"/>		"SOFT" = Rubber profile "NBR" with 85 "SPECIAL" shore (soft)	<input type="checkbox"/>		
"UV" = Резина "EPDM" твердостью 95 shore для машин печатающих УФ красками	<input type="checkbox"/>		"UV" = Rubber profile "EPDM" with 95 shore for "UV" ink printing machines	<input type="checkbox"/>		
ВАЖНО: По Вашему запросу все типы ножей могут быть изготовлены с применением специальной EPDM резины с твердостью 85 shore, необходимой для машин печатающих УФ-красками. МИНИМАЛЬНЫЙ ЗАКАЗ 10 ШТУК			IMPORTANT: On specific request, all the blades we manufacture can be supplied with special "EDPM" rubber profile with 85 shore, required for "UV" ink printing			

