



РУБАШКИ ДЛЯ МАШИН HEIDELBERG
JACKETS OF HEIDELBERG MACHINE

ROYAL PERFECTING CYLINDER JACKETS

®

РУБАШКИ ПЕРЕДАТОЧНОГО ЦИЛИНДРА
для машин HEIDELBERG

JACKETS FOR TRANSFER CYLINDERS
of HEIDELBERG machine

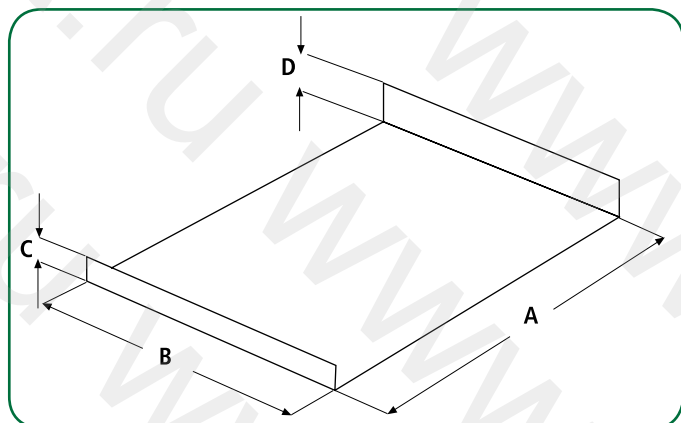

ДЛЯ ПЕРЕДАТОЧНОГО ЦИЛИНДРА - FOR TRANSFER CYLINDERS

КОД CODE	МОДЕЛЬ МАШИНЫ - MACHINE MODEL	РАЗМЕРЫ - SIZES				ТОЛЩИНА THICKNESS
		А мм	В мм	С мм	Д мм	
11316	PERFECTING "TRANSFER" CYLINDER JACKET SPEEDMASTER 52	390	532	9	25	0,30 мм
11325	PERFECTING "TRANSFER" CYLINDER JACKET SPEEDMASTER SM 74 CD - PM 74 (8 ОТВЕРСТИЙ - 8 HOLES)	546	748	25	6,5	0,30 мм
11326	PERFECTING "TRANSFER" CYLINDER JACKET SPEEDMASTER SM 74 CD - SM 75 XL	710	1030	12	24	0,30 мм
11335	PERFECTING "TRANSFER" CYLINDER JACKET SPEEDMASTER 102 (10 ЗАКЛЕПОК - 10 RIVETS)	532	747	22	12	
11336	PERFECTING "TRANSFER" CYLINDER JACKET SPEEDMASTER SM 105 XL	728	1051	8	8	



Каждая рубашка упакована в индивидуальный деревянный ящик



All our perfecting jackets are packed individually in wooden boxes.

oktoPRINT
SERVICE

ROYAL PERFECTING IMPRESSION JACKETS

РУБАШКИ ДЛЯ ПЕЧАТНОГО ЦИЛИНДРА для
машин HEIDELBERG

JACKETS FOR IMPRESSION CYLINDERS
for HEIDELBERG machine

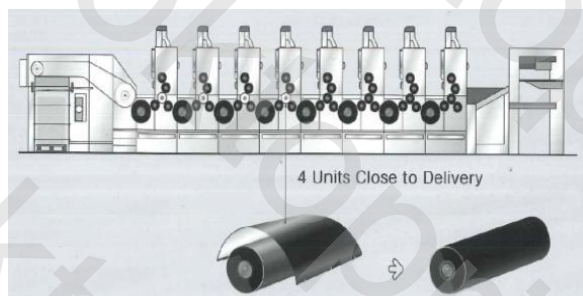
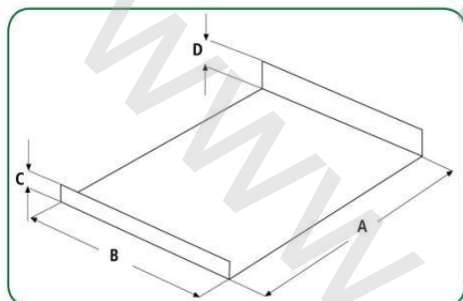

КОД CODE CODIGO	МОДЕЛЬ МАШИНЫ - MACHINE MADEL - MAQUINA MODELO	РАЗМЕРЫ- SIZES - MEDIDAS			
		A mm	B mm	C mm	D mm
11300	PERFECTING JACKET GTO 46	393	458	-	26
11305	PERFECTING JACKET GTO 52	408	518	-	26
11310	PERFECTING JACKET GTO MO	545	660	-	26
11315	PERFECTING JACKET GTO SPEEDMASTER 52	390	530	9	15
11320	PERFECTING JACKET GTO SPEEDMASTER 72	533	738	8	17
11322	PERFECTING JACKET GTO SPEEDMASTER 74	533	753	10	15
11330*	PERFECTING JACKET GTO SPEEDMASTER 102	716	1039	7	17

«ROYAL REFINED PERFECTING CYLINDER JACKETS»
FOR IMPRESSION CYLINDERS FOR HEIDELBERG

OEM PART N°	КОД	ОПИСАНИЕ ПРОДУКТА
52.581.173.N	11300	ROYAL PERFECTING IMPRESSION JACKET GTO 46 (THICKNESS 0,31MM/0,315MM)
79.581.173.N	11305	ROYAL PERFECTING IMPRESSION JACKET GTO 52 (THICKNESS 0,31MM/0,315MM)
G2.581.173.N	11315	ROYAL PERFECTING IMPRESSION JACKET SM 52 (THICKNESS 0,31MM/0, 315MM)
53.581.173.N	11310	ROYAL PERFECTING IMPRESSION JACKET MO (THICKNESS 0,31MM/0,315MM)
93.581.173.N	11320	ROYAL PERFECTING IMPRESSION JACKET SM 72 (THICKNESS 0,31MM/0,315MM)
M2.581.173.N	11322	ROYAL PERFECTING IMPRESSION JACKET SM74 (NO HOLES) (THICKNESS 0,31MM/0,315MM)
S9.581.173.N	11330	ROYAL PERFECTING IMPRESSION JACKET SM 102 (THICKNESS 0,31MM/0,315MM)